

WALL MOUNTED WALL FRAME SERIES



AGER Wall Mounted Wall Frame Series fits perfectly into businesses and facilities where small volumes are required with its decorative design and flexible installation ease.

There is no need for a closed cabinet structure in the wall-mounted open rack cabinet system. It is suitable for network applications in clean and dust-free environments.

Products that can be positioned inside; network access devices, wireless devices (Wireless Modem / Router), camera recorders (DVR), Telephone connection boxes (Buat or Splitter), Hub / Switch, External Disk, Ups Power Supply. Server Chassis, Computer etc.



Color Options

RAL7035 Light Grey

RAL9005 Black

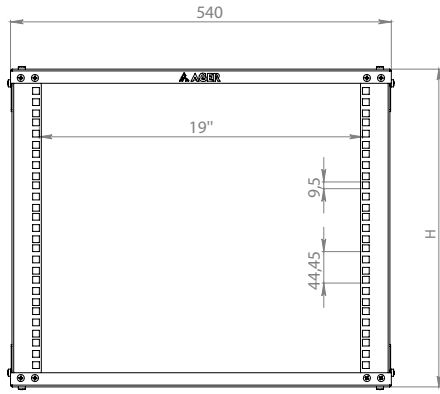

FRONT VIEW

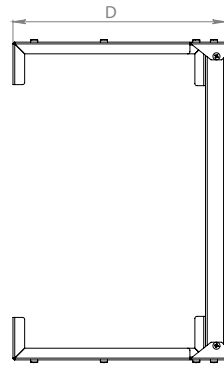

SIDE VIEW

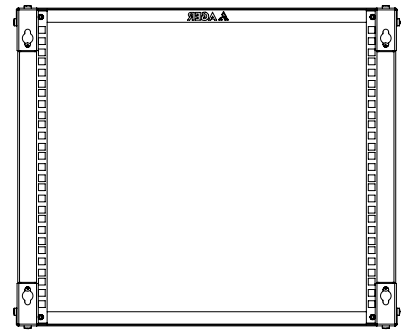

REAR VIEW

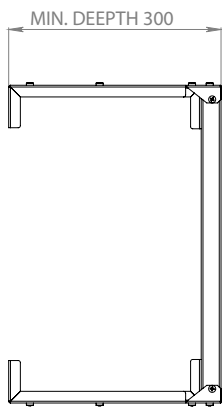

MIN. DEEPTH 300

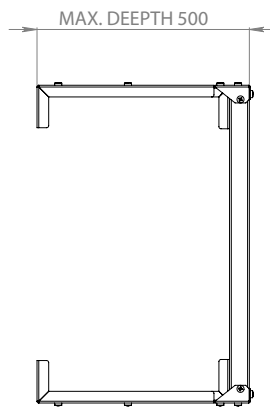

MAX. DEEPTH 500

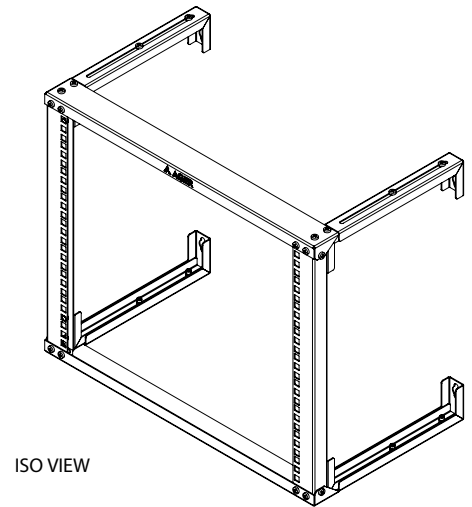

ISO VIEW

19" Ager Wall Type WALL FRAME Series

Product Code	Product Description	U Size (U)	Width (Between Mounting Rails)	Width (W) (mm)	Depth (D) (mm)	Height (H) (mm)	Weight (Net) (kg)	Weight (Gross) (kg)
AG-WF07U5430XX-A-D1	07U 19" Ager Wall Frame Cabinet W=540mm D=300mm	7U	19"	540	300-500	360	3,2	3,5
AG-WF09U5430XX-A-D1	09U 19" Ager Wall Frame Cabinet W=540mm D=300mm	9U	19"	540	300-500	448	3,4	3,7
AG-WF12U5430XX-A-D1	12U 19" Ager Wall Frame Cabinet W=540mm D=300mm	12U	19"	540	300-500	582	3,7	4,0
AG-WF16U5430XX-A-D1	16U 19" Ager Wall Frame Cabinet W=540mm D=300mm	16U	19"	540	300-500	760	4,1	4,4
AG-WF21U5430XX-A-D1	21U 19" Ager Wall Frame Cabinet W=540mm D=300mm	21U	19"	540	300-500	982	4,6	4,9

XX = Colour Code, B1 White RAL 7035, S1 Black RAL 9005, during order please specify the colour choice
 Please consider when used levelling feet 30mm add to Height, in castor add 80mm
 0000 = Please check the Door Options page
 YY = M1 for pre-assembled, D1 for flat pack