



AGER Data Center Solutions



Color Options

RAL7035 Light Grey

RAL9005 Black

DATA CENTER SYSTEMS



AGER Datacenter cabinets specifically designed for improving your data center infrastructures based on:

- Efficient cooling performance
- Flexibility on cabling variations and IT equipment layouts.
- Stability on very high loading capacity demands and seismic zone requirements
- Compatibility to Hot Aisle - Cold Aisle or Stand Alone infrastructures
- High Scalability for near or far future demands.

Various sizes are available for width : 600 / 800 mm ; height : 42U / 45U / 47U ; depth : 1000 / 1100 / 1200 mm. AGER Datacenter cabinets have an aesthetic appearance with their curved and high ventilation ratio perforated door structure. Various front and rear door options are also available according to your request. Main colour options, RAL 9005 Black and RAL 7035 Light Grey.

- Ergonomic and modern design for new-gen datacenter infrastructure
- High stability frame construction for Static loading capacity up to 1.500 kgs.
- Mounting rail positions are adjustable on depth direction for flexible equipment mounting.
- Max. Space for server equipment allocation and efficient ventilation
- IP20 protection level (acc. EN 60529)
- Doors are 80% perforated for optimized air circulation and high cooling efficiencies
- High opening stroke 180°on doors for easy installation , runtime and breakdown maintenance. (Standalone condition; for side by side joint : 165°)
- Standard Sizes :
 - Height : 42U - 45U -47U
 - Width : 600mm - 800mm
 - Depth :1000mm - 1100mm - 1200mm
 - Project based special sizes are possible.
- Compatible for Hot Aisle - Cold Aisle and Standalone configurations.
- Flexible cable routing and fixing options at top,bottom and inside of cabinets.
- Compatible for all types mechanical and electronic type locking systems.
- Multiple accessory options for top-zone and internal zone cable management ; air flow management.
- Maximum safety for User and minimum Earthing resistance for Equipments on electrical continuity.



COMPATIBILITY CHART

EN 60950-1	Information technology equipment - Safety Part 1: General requirements - CE compatibility
EN IEC 62368-1	Audio/video, information and communication technology equipment Part 1: Safety requirements
UL 60950-1- UL2416	Information Technology Equipment - Safety - Part 1: General Requirements - UL compatibility
EN 61587-1	Mechanical Structures For Electronic Equipment - Tests For IEC 60917 And IEC 60297 Series - Part 1: Environmental Requirements, Test Set-Up And Safety Aspects For Cabinets, Racks, Subracks And Chassis Under Indoor Conditions
2011/65/EU	The restriction of the use of certain hazardous substances in electrical and electronic equipment, RoHS
EN IEC 60068-3-3	Environmental testing - Part 3-3: Supporting documentation and guidance - Seismic test methods for equipment
EN 61587-1/4.2, IEC 60068-2-1, IEC 60068-2-2, IEC 60068-2-30	Climatic and environment
EN 61587-1/5.2.1	Static Mechanical Load Lifting
EN 61587-1/5.2.2	Static Mechanical Load Stiffness
EN 61587-1/5.3.1 EN 61587-1/5.3.3, IEC 60068-2-6, IEC 60068-2-27	Dynamic Mechanical Load Vibration and Shock, Impact
EN 61587-1/6.2	Earth Bond
EN 61587-1/6.3	Flammability
EN 61587-1/6.4	Degrees Of Protection Provided By Enclosures (Ip Code): IP20
EN 13501-1+A1 (Paint unflammability)	"Fire classification of construction products and building elements Part 1: Classification using data from reaction to fire tests. Paint unflammability Classification: A2-S1,d0"
EN 13501-1+A1 (Polycarbonate closure unflammability)	Fire classification of construction products and building elements Part 1: Classification using data from reaction to fire tests. Polycarbonate closure unflammability Classification: B-S1,d0
EN 12150-1	Glass in building. Thermally toughened soda lime silicate safety glass Definition and description : Antistatic, edge grinded, tempered glass
EN IEC 60297	"Mechanical structures for electrical and electronic equipment. Dimensions of mechanical structures of the 482,6 mm (19 in) series"
EN IEC 60917	Modular order for the development of mechanical structures for electronic equipment practices - Part 1: Generic standard
EIA/ ECA-310 (D/E)	19" 482,6 mm and U 44,45 mm Height Sizing
EN ISO 9227	Corrosion tests in artificial atmospheres - Salt spray tests
EN ISO 2409	Paints and varnishes - Cross-cut test
TS 2311 EN ISO 2178	Non-magnetic coatings on magnetic substrates Measurement of coating thickness - Magnetic method
DIN EN 10130 - DC-01 6112 or 7122	Cold rolled low carbon steel flat products for cold forming. Technical delivery conditions
DIN 7985, DIN 965, DIN 7981, DIN 934, DIN 985, DIN 933 - EN ISO 2081	"Metallic and other inorganic coatings - Electroplated coatings of zinc with supplementary treatments on iron or steel (screw, nut, washer,etc)"

Production Facility Standards

ISO 9001:2015	Quality Management System
ISO 14001:2015	Environmental Management System



CABINET STRUCTURE

AGER DC cabinet strength is based joining welded front and rear frames with strong multibended depth profiles. Multibend depth profiles fixed to front and rear frames with high quality steel fittings. AGER DC Special design frame is an ideal solution for safely mounting of your heavy equipments up to recommended loading capacity.

Cabinet frames can be mounted side by side. Cabinets are suitable for offices, system rooms and datacenter aisle containments for network, server or cabling purposes. DC cabinets are compatible with all types and brands of 19" network server devices and accessories.

Thanks to easily removable side panels, front and rear doors, top and bottom covers ; full easy access from any direction can be provided during installation, maintenance and repair. Wide internal volume provides various types of cable and wire management for all devices and equipments.

All panel, door and accessory options can be easily applied based on customer demands. Panels and doors are lockable and can be managed with same key pattern.



FRONT DOORS

AGER Datacenter cabinet standard front door option is 80% perforated and curved.

Hexagonal shaped holes with 80% perforation provides maximum air-flow for ventilation, while its double-sided full length welded structure provides extra strength to door frame.

Curved structure provides extra strength , aesthetic appearance to perforated zone. Curved zone also provides extra space for internal equipments front panel add-ons or accessories.

Swing handle lock with 4-point locking mechanism helps for maximum sturdiness and security.

The front doors with a spring hinge system provide ease of installation and use, as they can be easily disassembled and attached without tools when needed.

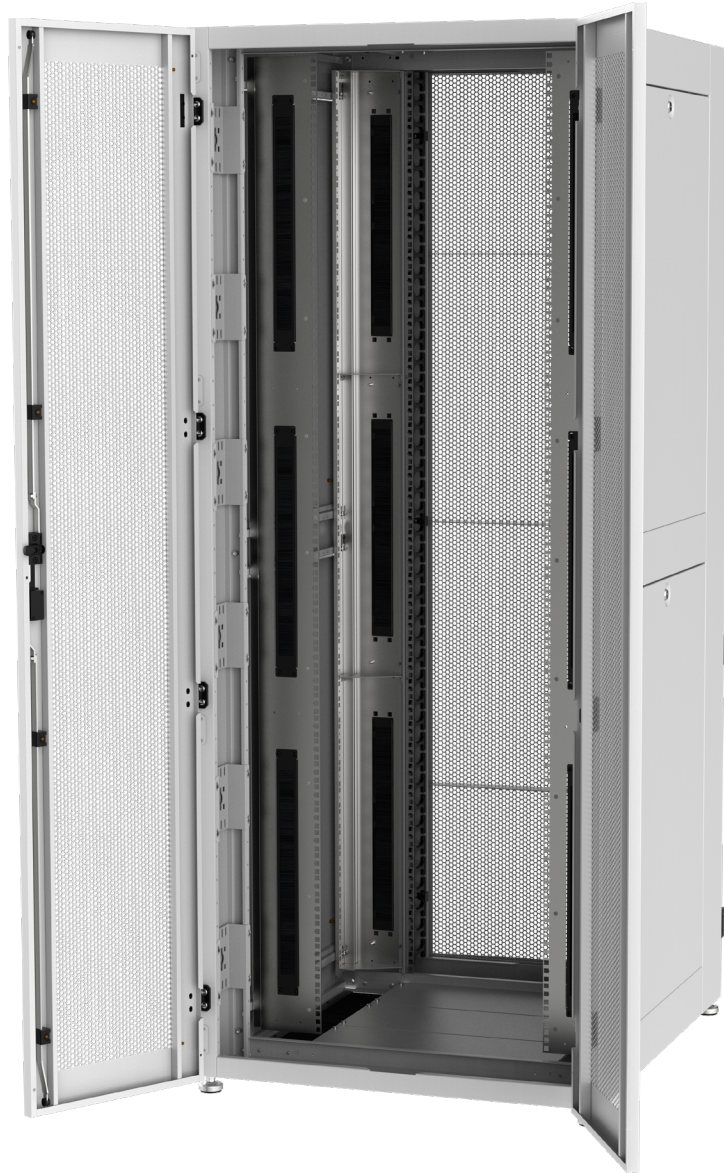

REAR DOOR

AGER Datacenter cabinet standard rear doors have 80% perforation ratio. Vertically divided and flat structure provides minimum space demand between any wall or obstacle to cabinet.

Hexagonal shaped holes with 80% perforation provides maximum air-flow for ventilation.

The hinged structure of vertically split rear double doors allows you to open rear doors easily in narrow spaces and access to the cabinet.

Swing handle lock with 3-point locking mechanism helps for maximum security.

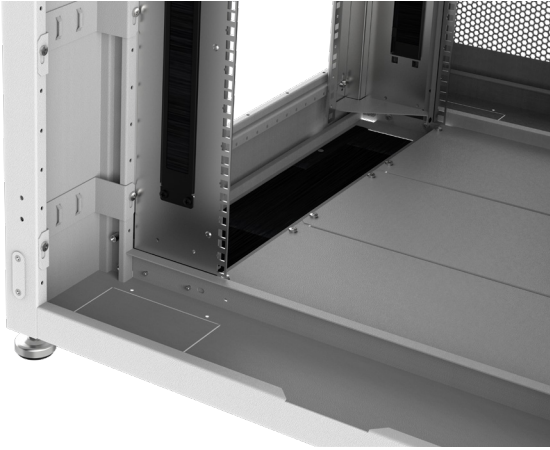

BOTTOM & TOP ACCESS POINTS

There are four micro-joint cutouts in corners of each top and bottom frames with 100 x 150 mm space. These points can be used as inlet or outlets for any cable plug or suitable equipments. These spaces can be closed with brush accessories for protection against dust or solid contaminations.

There are brush cable entry spaces located as left and right on both top and bottom frames. These large entry spaces provides high amount of cable passage or big sized plugs or accessories .

Divided blank panels are provides protection against bottom interventions, can be removed if any inlet needed. Also can be manually processed to add cable glands or any other hole passages..

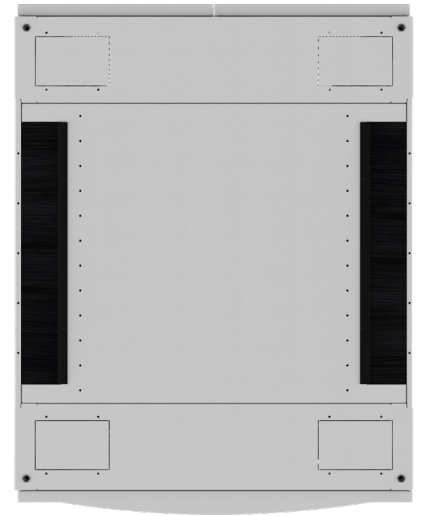

U MARKING

U height marking is applied as serigraphy to the mounting rails of the cabinet which helps to index of the devices mounted in the cabinets. These markings are also helpful to mount your equipments in proper positions and preventing risks of left and right misalignments during installations.

TOP MOUNTED CABLE ROUTING SEPERATORS

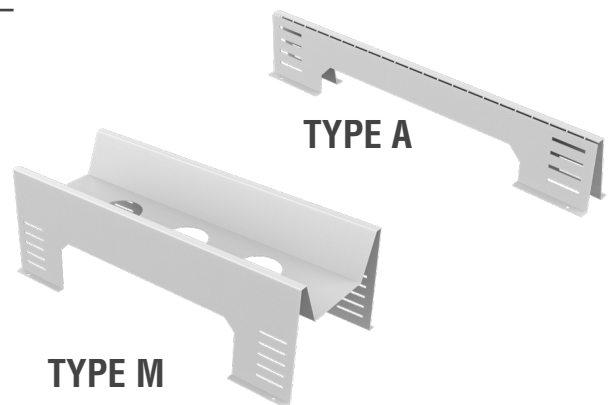

Separators offer professional and secured management of high density data and power cables which flows over the cabinets row. Separating data and energy cables with separators and dividers , is important to minimize electromagnetic and physical interference.

Separators can be easily mounted on the cabinets with screws in order to separate the data and electrical cables from each other. Its easy to adjust the position all along the Cabinet depth.

SEISMIC FIXING KIT



Seismic Fixing kits developed to reduce risks against equipment safety in case of any seismic actions. Strengthened crisscross mechanism provides high stability but also behaves as shock-absorbing unit to protect cabinets. With these kits you can safely fix cabinets to ground level.

19" Ager DC Cabinet Seismic Fixing Kit	
Product Code	Product Description
AG-DCDK6010-A	19" AgerDC Data Center Cabinet Seismic Fixing Kit W=600mm D=1000mm
AG-DCDK8010-A	19" AgerDC Data Center Cabinet Seismic Fixing Kit W=800mm D=1000mm
AG-DCDK6011-A	19" AgerDC Data Center Cabinet Seismic Fixing Kit W=600mm D=1100mm
AG-DCDK8011-A	19" AgerDC Data Center Cabinet Seismic Fixing Kit W=800mm D=1100mm
AG-DCDK6012-A	19" AgerDC Data Center Cabinet Seismic Fixing Kit W=600mm D=1200mm
AG-DCDK8012-A	19" AgerDC Data Center Cabinet Seismic Fixing Kit W=800mm D=1200mm

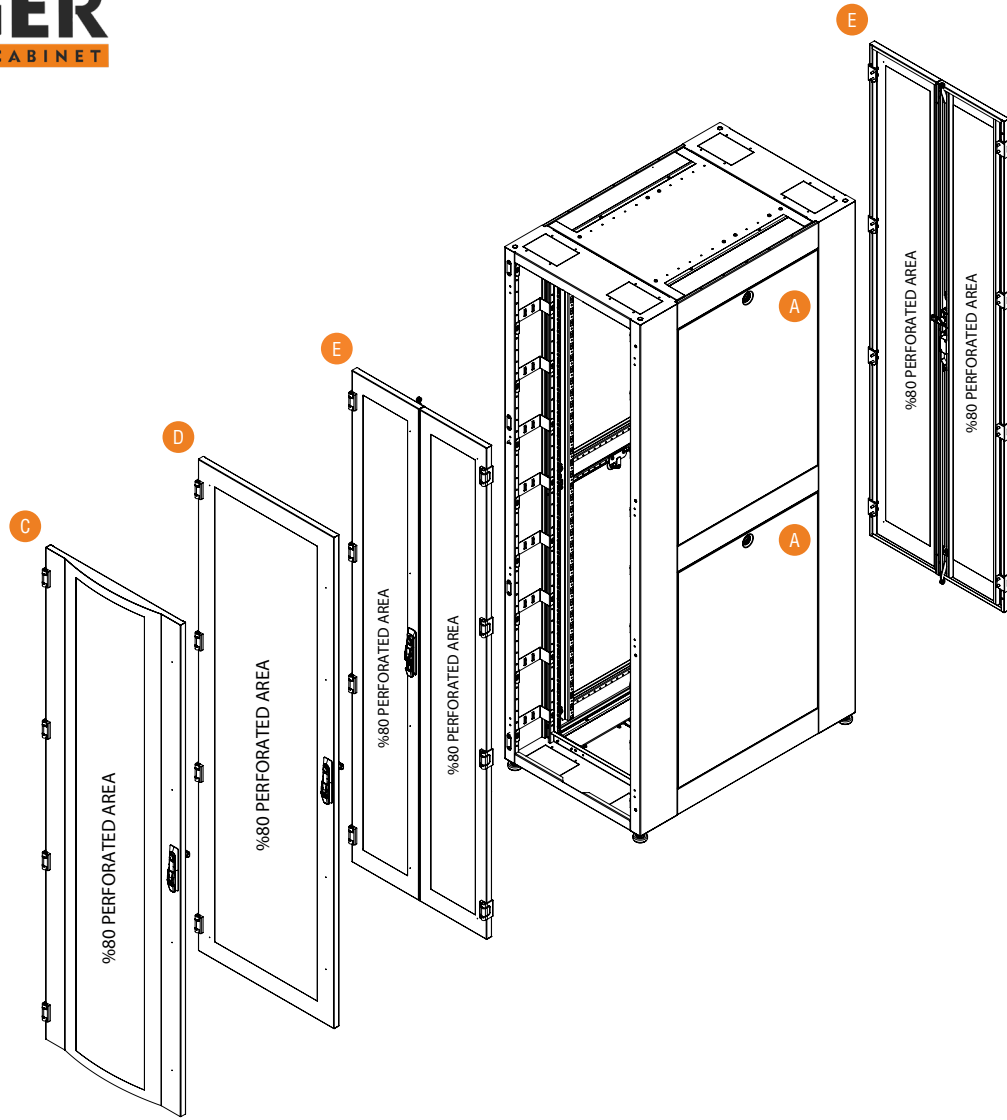

1. Company product coding system's initial character is AG that stands for ...
2. Product Series Code. DC free standing cabinets.
3. Numeric Character defining the height of the cabinet. Depending on model differences, between 42 to 47 height variety available. U Height Alphanumeric. Notation is fixed, not editable. 1U is 44.45mm.
4. The First two Digits of the width information. 60 for W=600 cabinets, 80 for W:800mm cabinets.
5. The First two Digits of the depth information, 10 for D:1000mm cabinets, 11 for D:1100mm cabinets, 12 for D:1200mm cabinets.
6. Colour Codes. B1 for Light Gray RAL 7035 and S1 for Black RAL 9005.
7. Front door variation number.*
8. Rear door variation number*
9. Right Side Panel variation number.*
10. Left Side Panel variation number.*
11. Version information. A- Standart version. The version is changed alphabetically when any alteration made to the cabinet
12. Indicate how the cabinets' shipped. M1 for assembled and D1 for flat pack.

Free Standing DC Series Door Options.

- A** Single Opening, Flat Shaped, Solid Metal, Snap Locking and Single point Locking with Barrel Lock, Panel.
- C** Single Opening, Curved, %80 Perforated Front Door, 4 Point Locking with Swing Handle.
- D** Single Opening, Flat Shaped, %80 Perforated Front Door, 4 Point Locking with Swing Handle.
- E** Double Opening, Flat Shaped, %80 Perforated Front Door, 3 Point Locking with Swing Handle.

***YOU CAN CHECK THE DOOR OPTIONS FOR DOOR AND PANEL OPTIONS...**

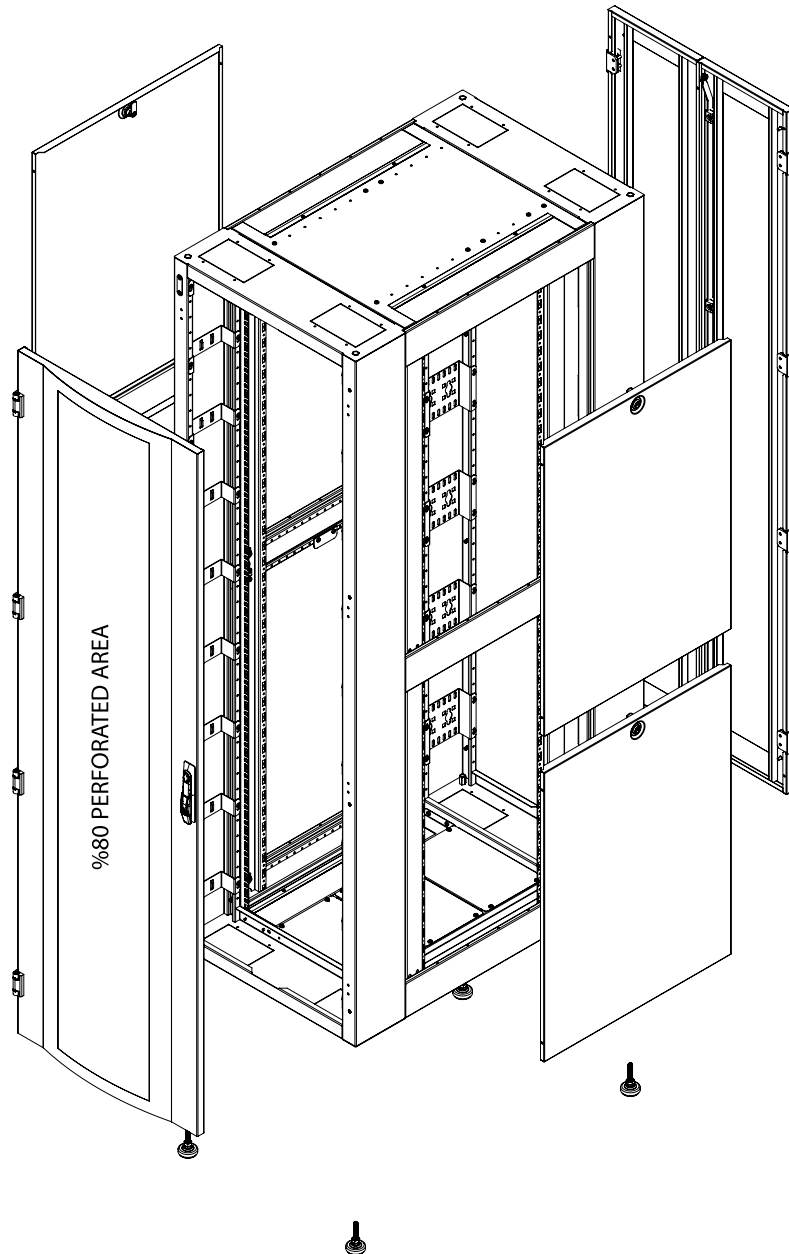

Material

- 1,5 mm DKP

IP Classification

- As a standard IP20
- IP40 when solid metal panel applied for all access

Loading Capacity

- Recommended up to 1500 kg Loading capacity

Side Panels

- Locking system is available, side panels are removable.

Doors

- Door options are available.
- Front door 4 point locking system and Rear Door 3 point locking system
- Doors can be opened to 180 degree.
- Doors can be opened to left or right direction

Mounting Rails

- 19" Mounting rails; adjustable in depth of the cabinet
- 1.5mm DX51D galvanic

Bottom Sheet

- It can be used completely open as well as detachable blank panels in standard configuration.

Ground Contact

- Caster and levelling feet options are available
- Plinth is available as an option.

Top Sheet

- Fan module is available as an option.

Color Options

- RAL9005 Black
- RAL7035 White

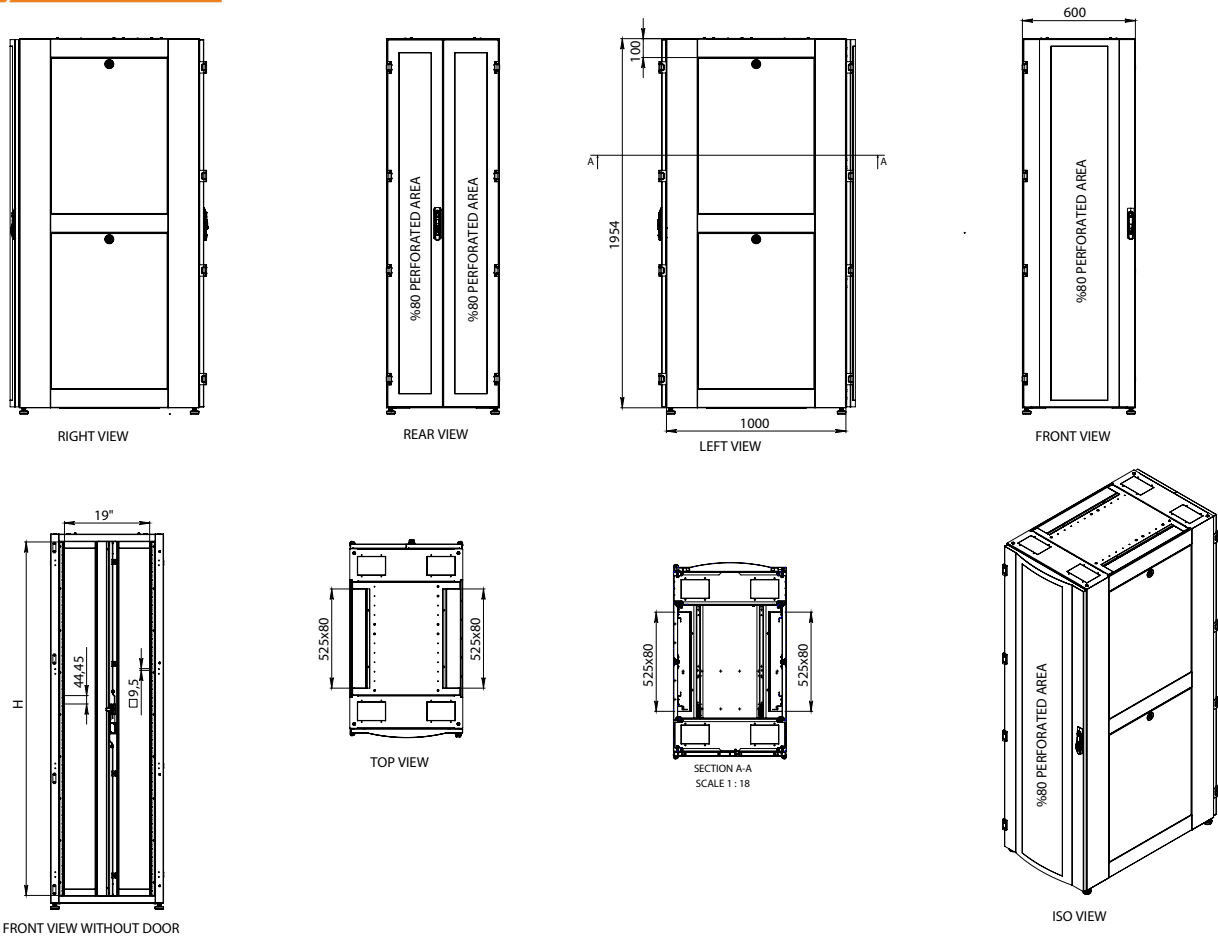

19" Ager DC Cabinets W=600mm D=1000mm

Product Code	Product Description	Height Size in U	Width (w) (mm)	Depth (D) (mm)	Height (H) (mm)	Weight (Net) (kg)	Weight (Gross) (kg)
AG-DC42U6010XX-0000-SR-YY	42U 19" AgerDC Data Center Cabinet W=600mm D=1000mm	42U	600	1000	1950		
AG-DC45U6010XX-0000-SR-YY	45U 19" AgerDC Data Center Cabinet W=600mm D=1000mm	45U	600	1000	2084		
AG-DC47U6010XX-0000-SR-YY	47U 19" AgerDC Data Center Cabinet W=600mm D=1000mm	47U	600	1000	2172		

19" Ager DC Cabinets W=600mm D=1100mm

Product Code	Product Description	Height Size in U	Width (w) (mm)	Depth (D) (mm)	Height (H) (mm)	Weight (Net) (kg)	Weight (Gross) (kg)
AG-DC42U6011XX-0000-SR-YY	42U 19" AgerDC Data Center Cabinet W=600mm D=1100mm	42U	600	1100	1950		
AG-DC45U6011XX-0000-SR-YY	45U 19" AgerDC Data Center Cabinet W=600mm D=1100mm	45U	600	1100	2084		
AG-DC47U6011XX-0000-SR-YY	47U 19" AgerDC Data Center Cabinet W=600mm D=1100mm	47U	600	1100	2172		

19" Ager DC Cabinets W=600mm D=1200mm

Product Code	Product Description	Height Size in U	Width (w) (mm)	Depth (D) (mm)	Height (H) (mm)	Weight (Net) (kg)	Weight (Gross) (kg)
AG-DC42U6012XX-0000-SR-YY	42U 19" AgerDC Data Center Cabinet W=600mm D=1200mm	42U	600	1200	1950		
AG-DC45U6012XX-0000-SR-YY	45U 19" AgerDC Data Center Cabinet W=600mm D=1200mm	45U	600	1200	2084		
AG-DC47U6012XX-0000-SR-YY	47U 19" AgerDC Data Center Cabinet W=600mm D=1200mm	47U	600	1200	2172		

XX = Colour Code, B1 White RAL 7035, S1 Black RAL 9005, this information should be told to the sales representative when requested.
 Please consider when used levelling feet 30mm add to Height, in castor add 80mm
 0000 = Please check the Door Options page
 YY = M1 for pre-assembled, D1 for flat pack.

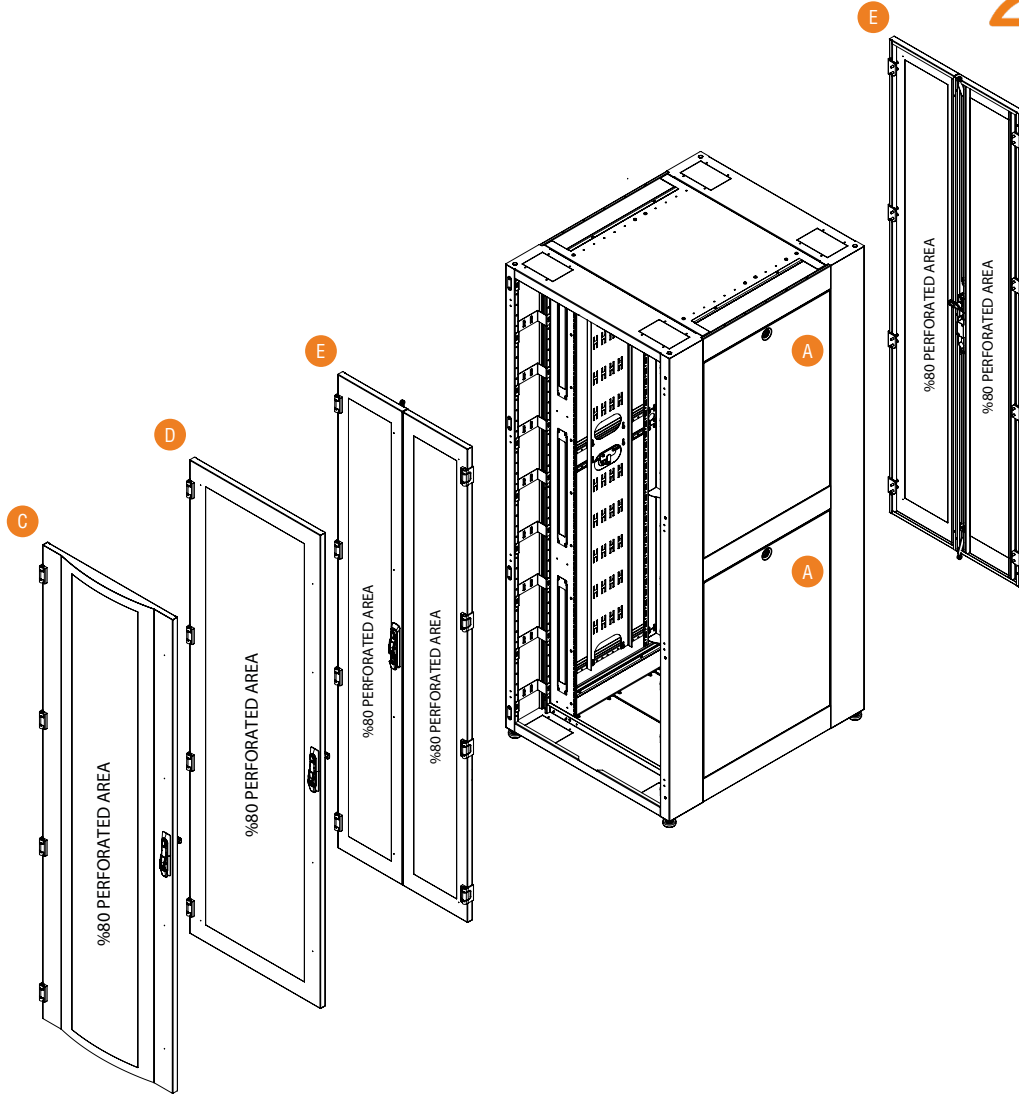

1. Company product coding system's initial character is AG that stands for AGER.

2. Product Series Code. DC free standing cabinets.

3. Numeric Character defining the height of the cabinet. Depending on model differences, between 42 to 47 height variety available. U Height Alfanumeric. Notation is fixed, not editable. 1U is 44.45mm.

4. The First two Digits of the width information. 60 for W=600 cabinets, 80 for W:800mm cabinets.

5. The First two Digits of the depth information, 10 for D:1000mm cabinets, 11 for D:1100mm cabinets, 12 for D:1200mm cabinets.

6. Colour Codes. B1 for Light Gray RAL 7035 and S1 for Black RAL 9005.

7. Front door variation number.*

8. Rear door variation number*

9. Right Side Panel variation number.*

10. Left Side Panel variation number.*

11. Version information. A- Standart version. The version is changed alphabetically when any alteration made to the cabinet

12. Indicate how the cabinets' shipped. M1 for assembled and D1 for flat pack.

Free Standing DC Series Door Options.

A Single Opening, Flat Shaped,Solid Metal,Snap Locking and Single point Locking with Barrel Lock, Panel.

C Single Opening, Curved, %80 Perforated Front Door, 4 Point Locking with Swing Handle

D Single Opening, Flat Shaped, %80 Perforated Front Door, 4 Point Locking with Swing Handle

E Double Opening, Flat Shaped, %80 Perforated Front Door, 3 Point Locking with Swing Handle.

***YOU CAN CHECK THE DOOR OPTIONS FOR DOOR AND PANEL OPTIONS...**

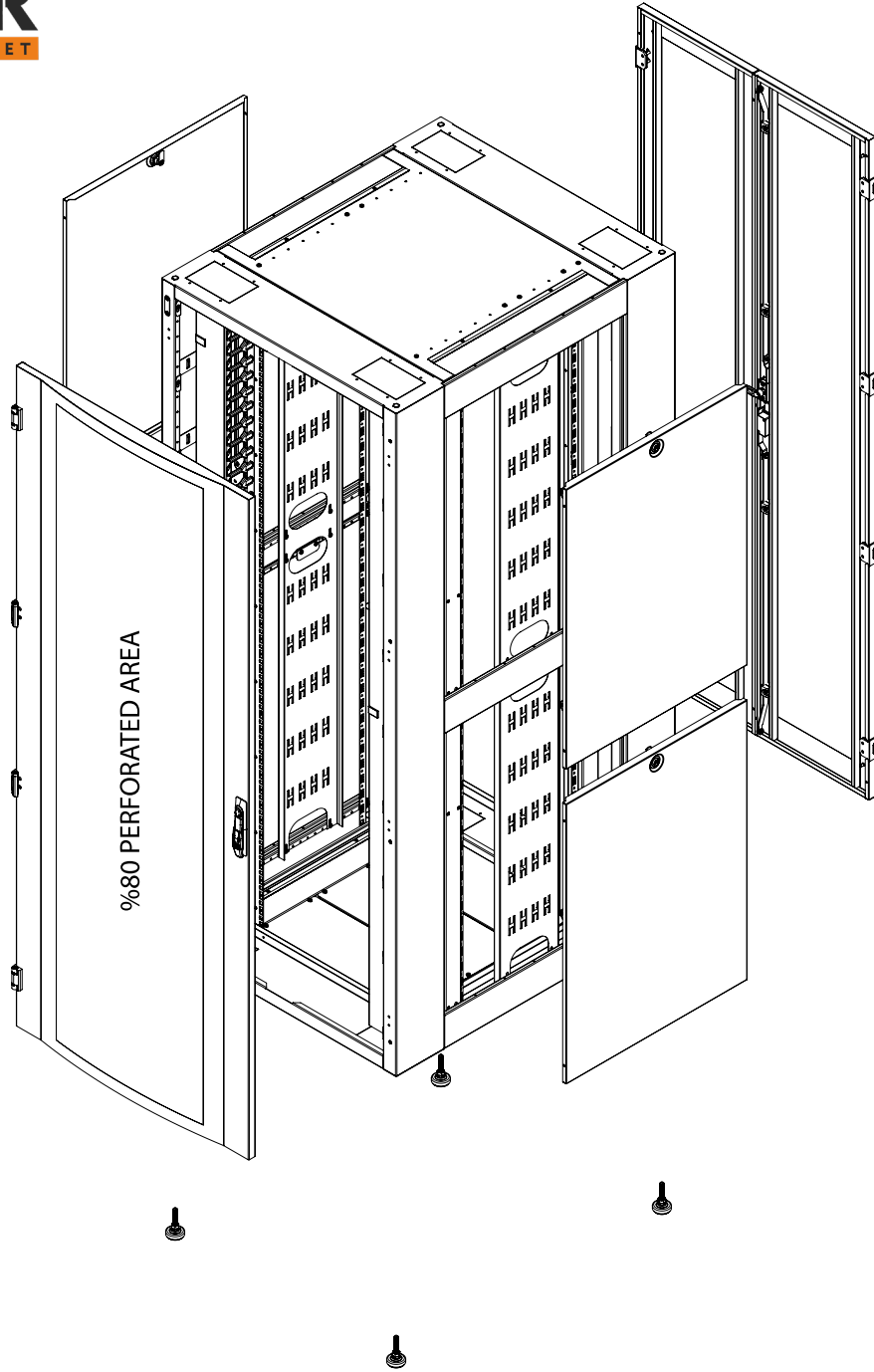

Material

- 1,5 mm DKP

IP Classification

- As a standard IP20
- IP40 when solid metal panel applied for all access

Loading Capacity

- Recommended up to 1500 kg Loading capacity

Side Panels

- Locking system is available, side panels are removable.

Doors

- Door options are available.
- Front door 4 point locking system and Rear Door 3 point locking system
- Doors can be opened to 180 degree.
- Doors can be opened to left or right direction

Mounting Rails

- 19" Mounting rails; adjustable in depth of the cabinet
- 1.5mm DX51D galvanic

Bottom Sheet

- It can be used completely open as well as detachable blank panels in standard configuration.

Ground Contact

- Caster and levelling feet options are available
- Plinth is available as an option.

Top Sheet

- Fan module is available as an option.

Color Options

- RAL9005 Black
- RAL7035 White

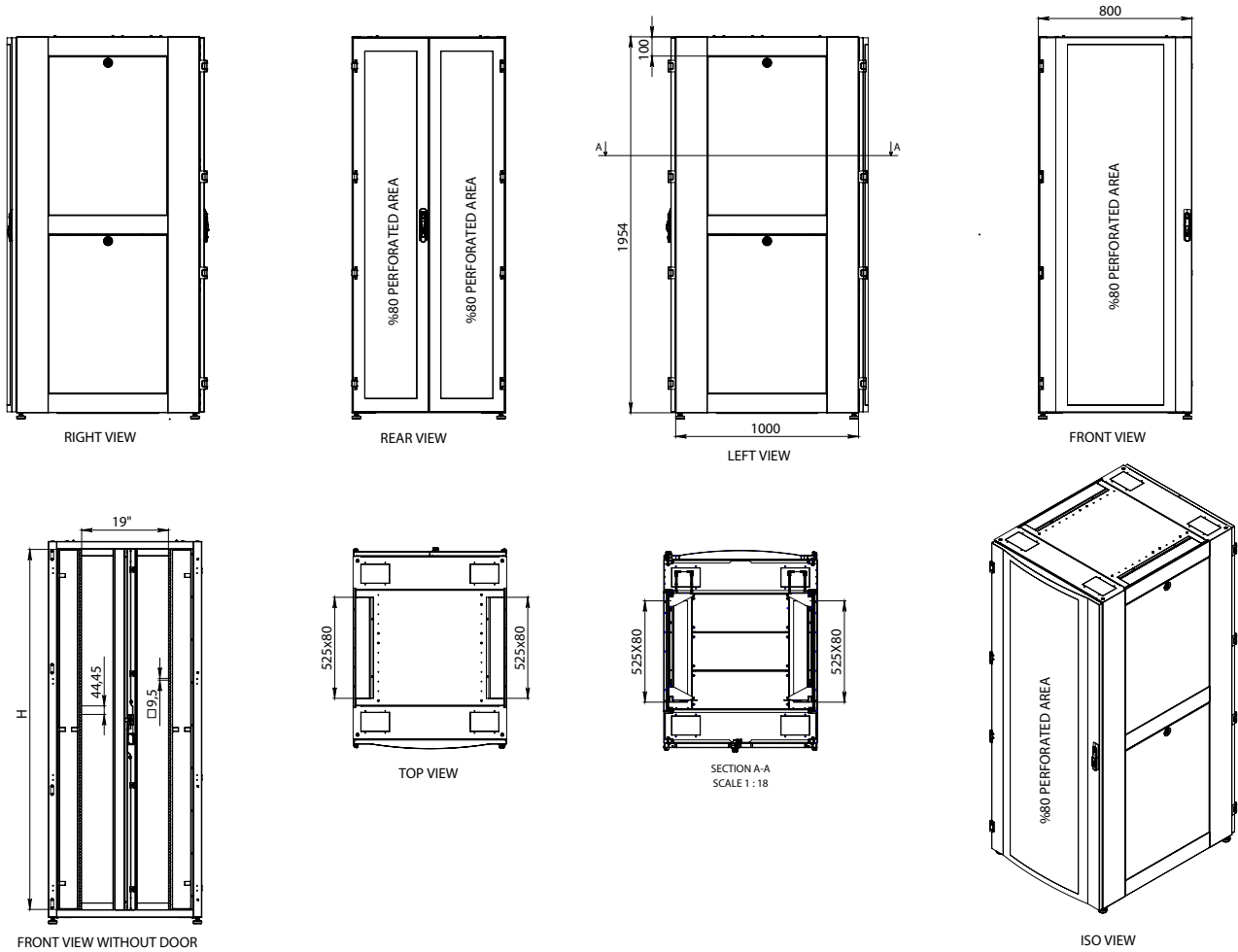

19" Ager DC Cabinets W=800mm D=1000mm

Product Code	Product Description	Height (h) Size in U (h)	Width (w) (mm)	Depth (d) (mm)	Height (H) (mm)	Weight (Net) (kg)	Weight (Gross) (kg)
AG-DC42U8010XX-0000-A-YY	42U 19" AgerDC Data Center Cabinet W=800mm D=1000mm	42U	800	1000	1950		
AG-DC45U8010XX-0000-A-YY	45U 19" AgerDC Data Center Cabinet W=800mm D=1000mm	45U	800	1000	2084		
AG-DC47U8010XX-0000-A-YY	47U 19" AgerDC Data Center Cabinet W=800mm D=1000mm	47U	800	1000	2172		

19" Ager DC Cabinets W=800mm D=1100mm

Product Code	Product Description	Height (h) Size in U (h)	Width (w) (mm)	Depth (d) (mm)	Height (H) (mm)	Weight (Net) (kg)	Weight (Gross) (kg)
AG-DC42U8011XX-0000-A-YY	42U 19" AgerDC Data Center Cabinet W=800mm D=1100mm	42U	800	1100	1950		
AG-DC45U8011XX-0000-A-YY	45U 19" AgerDC Data Center Cabinet W=800mm D=1100mm	45U	800	1100	2084		
AG-DC47U8011XX-0000-A-YY	47U 19" AgerDC Data Center Cabinet W=800mm D=1100mm	47U	800	1100	2172		

19" Ager DC Cabinets W=800mm D=1200mm

Product Code	Product Description	Height (h) Size in U (h)	Width (w) (mm)	Depth (d) (mm)	Height (H) (mm)	Weight (Net) (kg)	Weight (Gross) (kg)
AG-DC42U8012XX-0000-A-YY	42U 19" AgerDC Data Center Cabinet W=800mm D=1200mm	42U	800	1200	1950		
AG-DC45U8012XX-0000-A-YY	45U 19" AgerDC Data Center Cabinet W=800mm D=1200mm	45U	800	1200	2084		
AG-DC47U8012XX-0000-A-YY	47U 19" AgerDC Data Center Cabinet W=800mm D=1200mm	47U	800	1200	2172		

XX = Colour Code, B1 White RAL 7035, S1 Black RAL 9005, this information should be told to the sales representative when requested.
 Please consider when used levelling feet 30mm add to Height, in castor add 80mm
 0000 = Please check the Door Options page
 YY = M1 for pre-assembled, D1 for flat pack.

AISLE CONTAINMENT SYSTEMS



Color Options

RAL7035 Light Grey

RAL9005 Black

AISLE CONTAINMENT SYSTEM

Aisle Containment systems separate conditioned cold air and hot air generated by servers and other IT equipments. Aisle structures are important to maximize the system efficiency , to minimize total power consumption and footprint of data storage by managing air flow. Aisle systems are convenient solutions for medium to large-scale data centers.

The Cold and Hot aisle containment systems are retrofittable to upgrade existing or old server rooms to improve their performances. Aisles are modular and scalable , which helps reducing future investments in case of growing needs. Our cold and hot Aisles can be expanded proportionally when you would like to increase your datacenter capacity.

ADVANTAGES

- More efficient than traditional cooling technologies up to 50% energy savings
- Increase server performance and cooling efficiency in Data Centers
- Retrofittable
- Compatible to GreenIT applications
- Compatible to Remote Monitoring
- High Security and reliability for system components
- Efficient energy management
- Customizable design options with various air conditioning solutions
- Maximize cooling system efficiency ; minimize cooling investment costs and operational costs
- High modularity and Scalability
- Optimum cooling solution for big and medium scale datacenter structures coupled with CRAC or Inrow cooling systems.

COLD AISLE CONTAINMENT

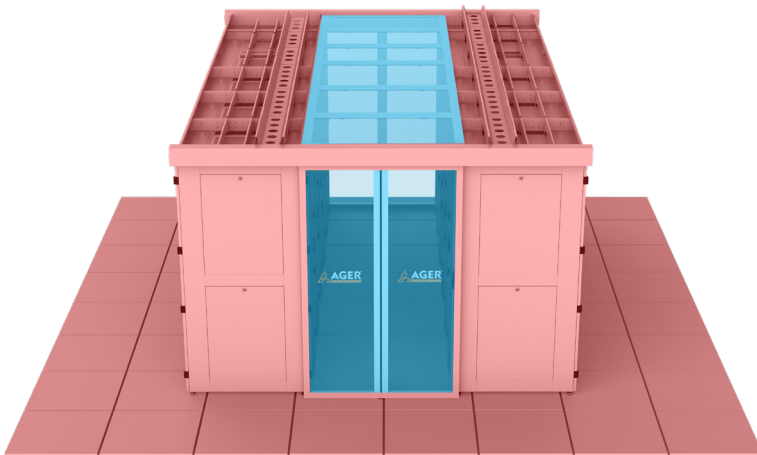

HOT AISLE CONTAINMENT

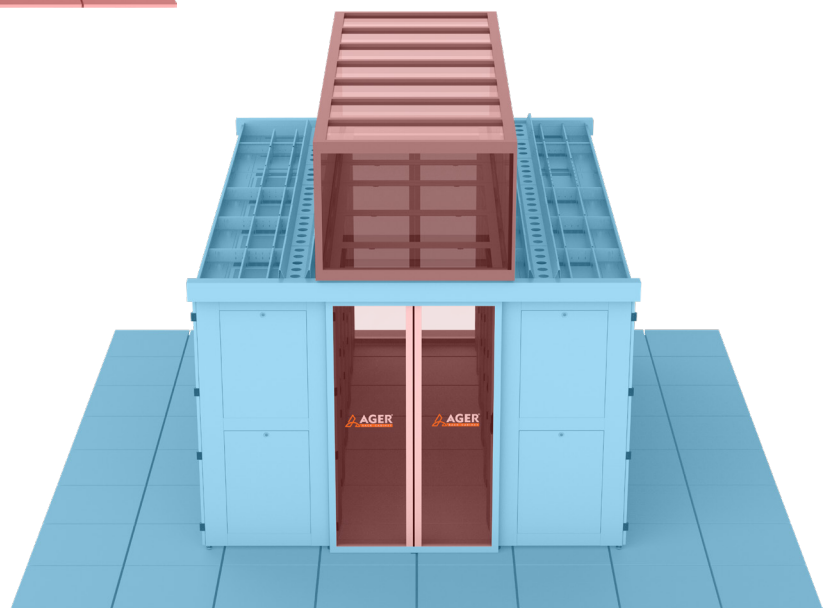

COLD AISLE CONTINMENT WITH INROW COOLING SOLUTIONS

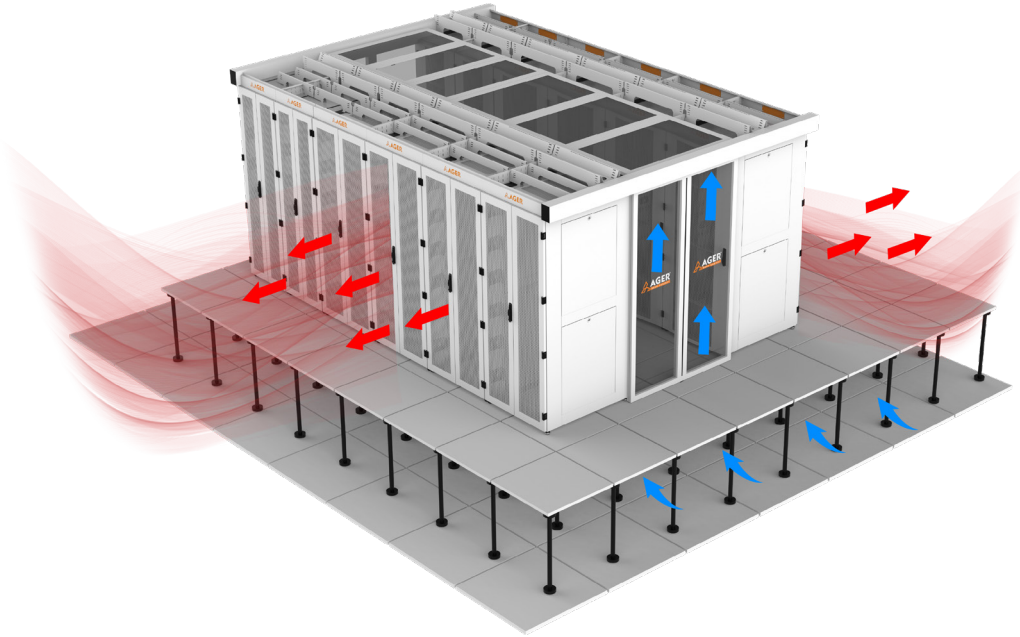

Cold aisle containment creates an enclosed corridor in front of server cabinets, ensuring that the coldest air flow towards directly into equipment air-intake zones. Airleak protection within entire cold aisle reduces unintended mixing of cold supply air with hot exhaust air. This precise protection maintains uniform desired temperatures across all rack layout.

HOT AISLE CONTINMENT WITH INROW COOLING SOLUTIONS

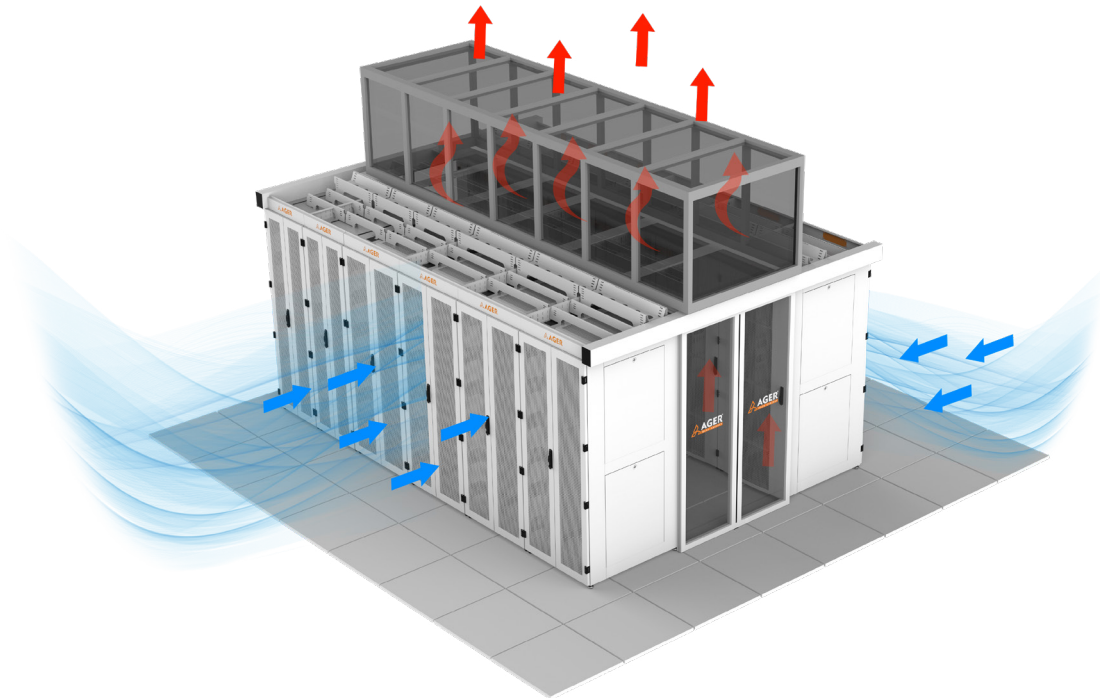

Hot aisle containment is the most common method for separating hot and cold air. Hot aisle containments have special channel structures to keep exhausted hot air away from equipments and evacuates it through cooling system. Data centers can maintain a stable operating temperature and reduce operational costs.

DATA CENTER SAFETY OPTIONS

RETRACTABLE ROOF SYSTEM

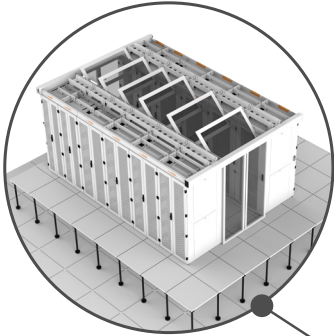

FIXED CEILING SYSTEM

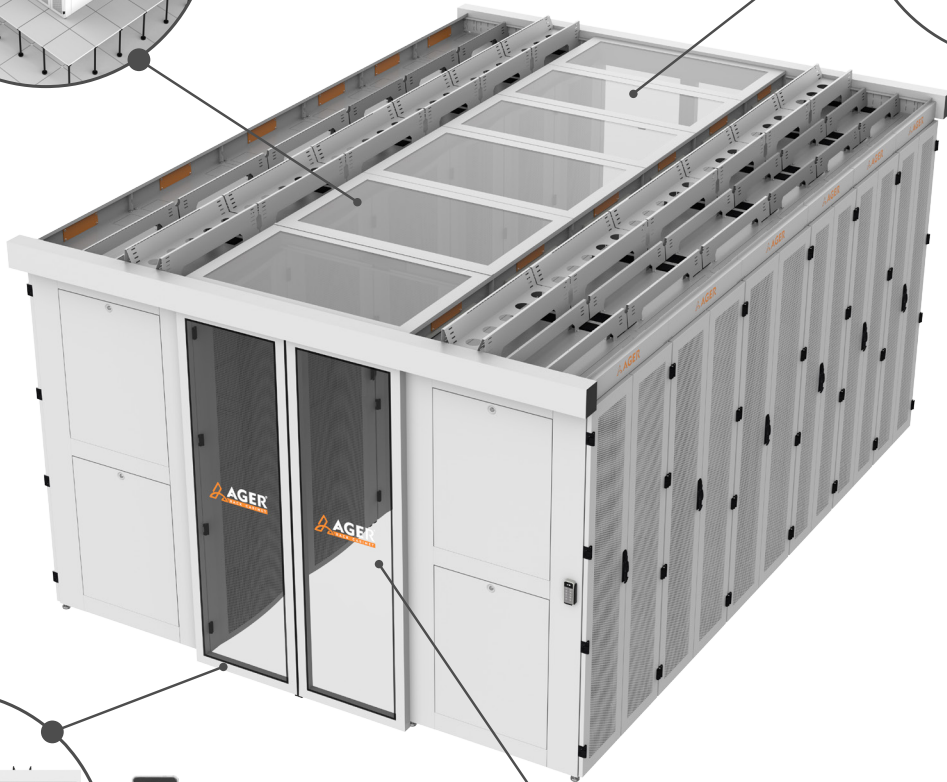
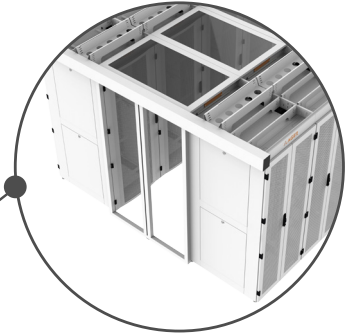

STANDARD HAND SENSOR

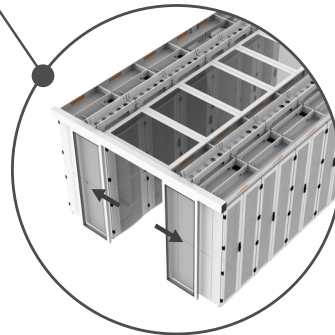

OPENING DOOR SYSTEM

Automatic sliding doors allow high lighting transparency.

- Various access controller options : Card Reader , Keypad or Fingerprint.
- Fixed top cover elements.

ROW-BASED INROW COOLING

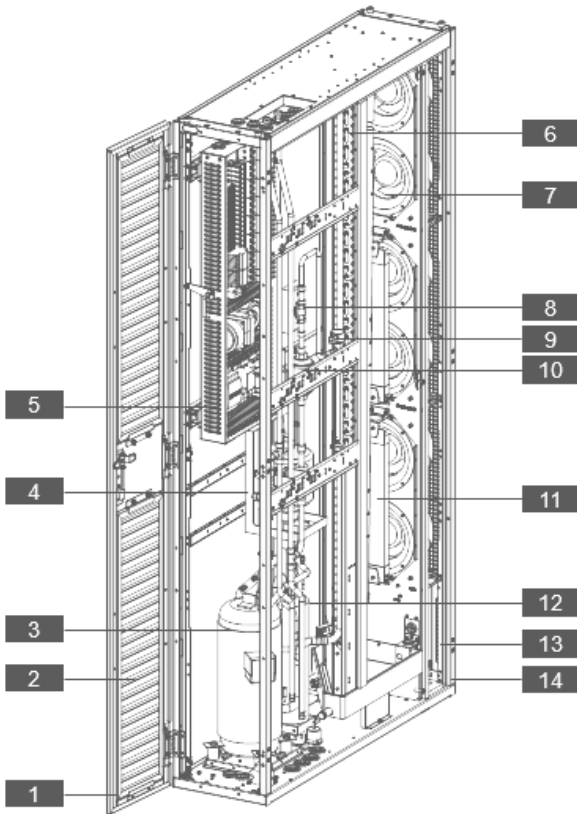

- 1 Rear door
- 2 Air filter
- 3 Compressor
- 4 Humidifier
- 5 Control box
- 6 Evaporator
- 7 Fans
- 8 Sight glass
- 9 EEV
- 10 Filter drier
- 11 Heater
- 12 Oil separator
- 13 Inverter
- 14 Front door

5-30 kW



40-65 kW



Standard Air Cooled Condenser



ROW-BASED INROW COOLING						
Product Code	Total Capacity - kW	Product Description	Width (w) (mm)	Depth (d) (mm)	Height (H) (mm)	Weight(W) (kg)
AGMDCIR13-42U110	12,8	42U 1100 12,8 KW INROW COOLING	300	1100	2000	233
AGMDCIR18-42U110	17,6	42U 1100 17,6 KW INROW COOLING	300	1100	2000	253
AGMDCIR22-42U110	21,2	42U 1100 17,6 KW INROW COOLING	300	1100	2000	258
AGMDCIR22-42U110	21,2	42U 1100 17,6 KW INROW COOLING	300	1100	2000	258
AGMDCIR26-42U110	25,1	42U 1100 25,1 KW INROW COOLING	300	1100	2000	260
AGMDCIR32-42U110	31,1	42U 1100 31,1 KW INROW COOLING	300	1100	2000	320
AGMDCIR41-42U110	40,9	42U 1100 40,9 KW INROW COOLING	600	1100	2000	360
AGMDCIR52-42U110	51,2	42U 1100 51,2 KW INROW COOLING	600	1100	2000	420
AGMDCIR66-42U110	65,7	42U 1100 65,7 KW INROW COOLING	600	1100	2000	460



AGER In-row air conditioners are tailor-made for all type datacenters. With its excellent cooling performance, precise temperature and humidity control, and high reliability, it provides the best operating environment for your key IT equipment.

- **Precise temperature control:**

Advanced temperature humidity sensors and control algorithms to achieve precise temperature control of ± 0.5 , ensuring that IT equipment operates within the optimal temperature range and extending the service life of the equipment.

- **Efficient cooling:**

High-efficiency compressors and heat exchangers, with large cooling capacity, high energy efficiency, and rapid response to load changes, effectively reducing energy consumption.

- **Modular design:**

The modular design is easy to install, maintain and expand, meets the needs of data centers of different sizes.

- **Cold and hot aisle isolation:**

It adopts cold and hot aisle isolation technology to effectively reduce the temperature of the aisle room and improve the cooling efficiency.

- **Intelligent control system:**

Equipped with an intelligent control system, which can realize remote monitoring, fault alarm and other functions, and facilitate management and maintenance.

- **Low noise operation:**

Advanced noise reduction technology, low operating noise, and ensures a quiet environment in the computer room.

- **Safe and reliable:**

Multiple protection measures to ensure the safe and reliable operation of the equipment and prevent the data center from shutting down due to faults.



EM-KS-002 rack mount LCD console features a 17” LCD display, ultra-slim keyboard / mouse and an 8-port KVM module in a 1U compact unit. An extra console port is provided on the rear panel to manage the LCD KVM switch from an external console.

The XL1708 integrates an 8 port analog KVM switch together with the LCD panel allowing access and control with up to 8 computers from a single console (keyboard, mouse, and monitor). By cascading additional switches, as many as 256 computers can be controlled from a single keyboard-monitor-mouse console.



Model		EM-KS-002
Computer Connections		8
Connectors		VGA(HDB-15 Female)
LCD Display	Display Type	SXGA TFT
	Display Size	17”
	Resolution	1280X1024@60Hz
	Display Color	16,7 M
	Brightness	250cd/m2 (T y p)
	Contrast ratio	1000 : 1(T y p)
Mouse	Pixel pitch(mm)	0.264(H) x 0.264(W)
	X/Y resolution	>1000 points /inch,(40 points/mm)
Touchpad with trackball		Eliminates the need for a separate, external mouse
Keyboard		99 keys (82 keys main keyboard +17 independent small number pad)
Port selection		Front panel pushbuttons, hotkeys, OSD menu
Power	Input Power	100V~ 240Vac , 50~60Hz , <1.5A
	Power consumption	17 W
Physical Characteristics	Operation temperature	0~40°C
	Storage temperature	-20~ 60°C
	Humidity	0~80% RH, non condensing
	Net weight	13.3 kg
	Product Dimension	448mmx581mmx42.5mm (WxDxH)
	Package Dimension	765mmx615mmx185mm (WxDxH)

RACK CABINET BEAM PANELS



RACK CABINET BEAM PANELS					
Product Code	Product Description	Width (w) (mm)	Depth (D) (mm)	Height (h) (mm)	
AG-DCALN30S1-A	DATA CENTER W=300 H=100MM BEAM PANELS WITHOUT LOGO (S1 BLACK)	300	50	100	
AG-DCALN60S1-A	DATA CENTER W=600 H=100MM BEAM PANELS WITHOUT LOGO (S1 BLACK)	600	50	100	
AG-DCALN80S1-A	DATA CENTER W=800 H=100MM BEAM PANELS WITHOUT LOGO (S1 BLACK)	800	50	100	

TOP COVER PANELS

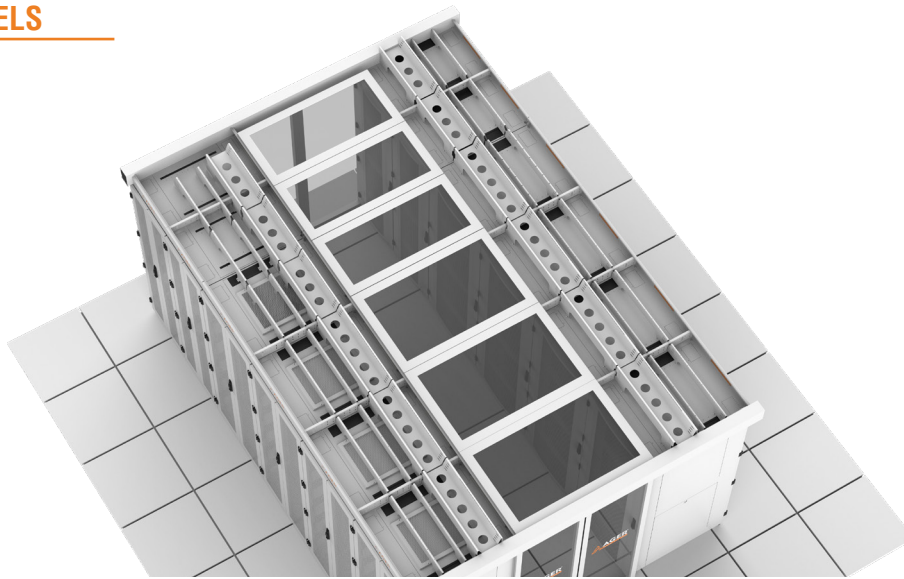

TOP COVER PANELS					
Product Code	Product Description	Width (w) (mm)	Depth (D) (mm)	Height (h) (mm)	
AG-DCTKP3012S1-B	DATA CENTER W=300 D=1200 CORRIDOR METAL FRAMED 10MM TRANSPARENT POLYCARBONATE CLAD CEILING COVER PANEL (S1 BLACK)	1200	300	20	
AG-DCTKP6012S1-B	DATA CENTER W=600 D=1200 CORRIDOR METAL FRAMED 10MM TRANSPARENT POLYCARBONATE CLAD CEILING COVER PANEL (S1 BLACK)	1200	600	20	
AG-DCTKP8012S1-B	DATA CENTER W=800 D=1200 CORRIDOR METAL FRAMED 10MM TRANSPARENT POLYCARBONATE CLAD CEILING COVER PANEL (S1 BLACK)	1200	800	20	
AG-DCTKP3012S1-B-K	DATA CENTER W=300 D=1200 CORRIDOR METAL FRAMED 10MM TRANSPARENT POLYCARBONATE CLAD CEILING COVER PANEL (S1 BLACK) END OF CORRIDOR	1200	300	20	
AG-DCTKP6012S1-B-K	DATA CENTER W=600 D=1200 CORRIDOR METAL FRAMED 10MM TRANSPARENT POLYCARBONATE CLAD CEILING COVER PANEL (S1 BLACK) END OF CORRIDOR	1200	600	20	
AG-DCTKP8012S1-B-K	DATA CENTER W=800 D=1200 CORRIDOR METAL FRAMED 10MM TRANSPARENT POLYCARBONATE CLAD CEILING COVER PANEL (S1 BLACK) END OF CORRIDOR	1200	800	20	

DOOR SECURITY OPTIONS



SLIDING DOOR



SLIDING DOOR

Product Code	Product Description	Width (w) (mm)	Depth (D) (mm)	Height (H) (mm)
AG-DCKKOC42U123600S1-A	DATA CENTER 42U D=1200 CABINET- CORRIDOR WIDTH=1200 CORRIDOR DOOR WITH HAND SENSOR (UPPER MECHANISM LENGTH 3600) AUTOMATIC FENCE WING GLASS - (S1 BLACK)	3600	180	2100
AG-DCKKOC42U103200S1-A	DATA CENTER 42U D=1000 CABINET-CORRIDOR WIDTH=1200 CORRIDOR DOOR WITH HAND SENSOR (UPPER MECHANISM LENGTH 3200) AUTOMATIC FENCE WING GLASS - (S1 BLACK)	3200	180	2100
AG-DCKKOC47U123600S1-A	DATA CENTER 47U D=1200 CABINET- CORRIDOR WIDTH=1200 CORRIDOR DOOR WITH HAND SENSOR (UPPER MECHANISM LENGTH 3600) AUTOMATIC FENCE WING GLASS - (S1 BLACK)	3600	180	2322
AG-DCKKOC47U103200S1-A	DATA CENTER 47U D=1000 CABINET-CORRIDOR WIDTH=1200 CORRIDOR DOOR WITH HAND SENSOR (UPPER MECHANISM LENGTH 3200) AUTOMATIC FENCE WING GLASS - (S1 BLACK)	3200	180	2322

SLIDING DOOR CONNECTION PROFILE

Product Code	Product Description	Width (w) (mm)	Depth (D) (mm)	Height (H) (mm)
AG-DCALN12020S1-A	DATA CENTER W=1200 H=100 BROWNING (S1 BLACK)	1200	30	100
AG-DCALN10020S1-A	DATA CENTER W=1000 H=100 BROWNING (S1 BLACK)	1000	30	100

TOP MOUNTED CABLE ROUTING SEPERATORS

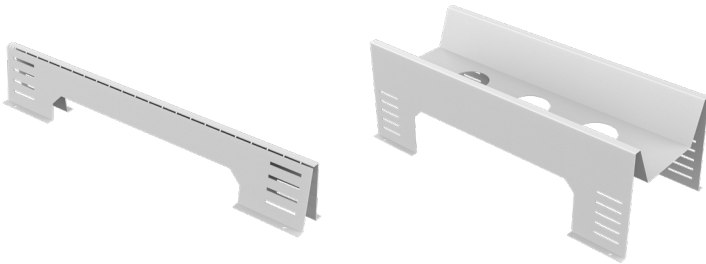

TOP - MOUNTED CABLE ROUTING SEPERATORS

Product Code	Product Description	Width (w) (mm)	Depth (D) (mm)	Height (H) (mm)
AA-DC-SPA60XX-A	DATA CENTER W=600 Top Mounted Cable Routing Separators (Type A)	595	60	101,5
AA-DC-SPA80XX-A	DATA CENTER W=800 Top Mounted Cable Routing Separators (Type A)	795	60	101,5
AA-DC-SPM60XX-A	DATA CENTER W=600 Top Mounted Cable Routing Separators (Type M)	595	261	201,5
AA-DC-SPM80XX-A	DATA CENTER W=800 Top Mounted Cable Routing Separators (Type M)	795	261	201,5

ENVIRONMENTAL MONITORING MODULE



Provides a scalable and intelligent monitoring infrastructure designed to ensure continuous control of critical environmental parameters in IT, edge data center, and industrial environments. Depending on the size of the monitored area and the required sensor types, the system can be flexibly expanded to support multiple sensors and monitoring points. This makes it an ideal solution for environments where environmental data must be collected and evaluated from more than one location simultaneously.

The module supports a wide range of sensors, including door sensors, temperature, humidity, and air quality sensors, as well as water leakage sensors, enabling comprehensive environmental supervision. An optional SMS module allows instant alarm notifications, ensuring rapid response to critical conditions.

ENVIRONMENT MONITORING MODULE							
Product Code	Product Description	Size (U)	Width (w) (mm)	Depth (D) (mm)	Height (H) (mm)	Weight (Net) (kg)	Weight (Gross) (kg)
AA-DC-EMS-1K-A	1 KABIN EMS MODULU (Main Modul (1), T&H Sensor (1), Smoke Sensor (1), Water Leakage Sensor (1), Door Sensor (2))	1U	482	-	-	-	-
AA-DC-EMS-2K-A	2 KABIN EMS MODULU (Main Modul (1), T&H Sensor (2), Smoke Sensor (2), Water Leakage Sensor (2), Door Sensor (4))	1U	482	-	-	-	-
AA-DC-EMS-3K-A	3 KABIN EMS MODULU (Main Modul (1), T&H Sensor (3), Smoke Sensor (3), Water Leakage Sensor (3), Door Sensor (6))	1U	482	-	-	-	-
AA-DC-EMS-4K-A	4 KABIN EMS MODULU (Main Modul (1), T&H Sensor (4), Smoke Sensor (4), Water Leakage Sensor (4), Door Sensor (8))	1U	482	-	-	-	-

(*SMS Module is an optional add-on to Main Module. Please contact to your Sales Representative for further details.)

ELECTRICAL DISTRIBUTION UNIT



Electrical Power Distribution Modules are specifically engineered to fully meet the electrical power distribution, control, and monitoring requirements of modern data center systems. Designed in compliance with international standards, these modules not only ensure reliable electrical performance but also offer ease of application and seamless integration. Full compatibility with a wide range of equipment and accessories enhances operational safety while supporting efficient and secure power management.

ELECTRICAL DISTRIBUTION UNIT							
Product Code	Product Description	Size (U)	Width (w) (mm)	Depth (D) (mm)	Height (H) (mm)	Weight (Net) (kg)	Weight (Gross) (kg)
AA-EDP03U19-10KVA-A-S1	19" Rack Mount - 10 kVA EDU (3 x 40 A – C Type – 3P MCB – 10 kA) (Main Power Supply - Residual Current Device – Precision A/C – UPS Power Supply – UPS Return Line – PDU Power Supply – Spare Circuit Breaker)	3U	482	123	133	8	10
AA-EDP03U19-15KVA-A-S1	19" Rack Mount - 15 kVA EDU (3 x 40 A – C Type – 3P MCB – 10 kA) (Main Power Supply - Residual Current Device – Precision A/C – UPS Power Supply – UPS Return Line – PDU Power Supply – Spare Circuit Breaker)	3U	482	123	133	8	10
AA-EDP03U19-20KVA-A-S1	19" Rack Mount - 20 kVA EDU (3 x 40 A – C Type – 3P MCB – 10 kA) (Main Power Supply - Residual Current Device – Precision A/C – UPS Power Supply – UPS Return Line – PDU Power Supply – Spare Circuit Breaker)	3U	482	123	133	8	10
AA-EDP03U19-30KVA-A-S1	19" Rack Mount - 30 kVA EDU (3 x 40 A – C Type – 3P MCB – 10 kA) (Main Power Supply - Residual Current Device – Precision A/C – UPS Power Supply – UPS Return Line – PDU Power Supply – Spare Circuit Breaker)	3U	482	123	133	8	10
AA-EDP03U19-40KVA-A-S1	19" Rack Mount - 40 kVA EDU (3 x 40 A – C Type – 3P MCB – 10 kA) (Main Power Supply - Residual Current Device – Precision A/C – UPS Power Supply – UPS Return Line – PDU Power Supply – Spare Circuit Breaker)	3U	482	123	133	8	10

AUTO TRANSFER SWITCH (ATS) MODULE

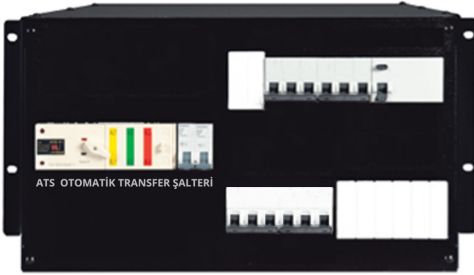

ATS Modules ; ensures continuous power supply by automatically transferring the load to the generator in the event of a failure of the primary power source. In general applications, it is installed at the generator location and continuously monitors the main power supply.

In the event of a power outage or voltage and frequency fluctuations that fall outside defined limits, the ATS initiates the generator start sequence. Once the generator reaches stable voltage and frequency levels, the ATS transfers the load to the generator supply. When grid power is restored and remains stable for a defined cooling-down period, the generator is automatically shut down and the

ATS returns to normal operation. All these operations are carried out automatically without the need for human intervention. Since the Automatic Transfer Switch (ATS) panel is connected between the primary and backup power sources, it acts as an electrically interlocked switching device, ensuring safe and reliable power transfer between sources.

AUTO TRANSFER SWITCH (ATS) MODULE								
Product Code	Product Description	Size (U)	Width(w) (mm)	Depth (D) (mm)	Height (H) (mm)	Weight (Net) (kg)	Weight (Gross) (kg)	
AA-EDP06U19-10KVA-ATS-A-S1	19" Rack Mount - 10 kVA Rated Power ATS MODULE (4 x 63 A I-II Coil Operated ATS , 3 x 40 A - C Type - 3P MCB - 10 kA) (Main Power Supply - Residual Current Device - Precision A/C - UPS Power Supply - UPS Return Line - PDU Power Supply - Spare Circuit Breaker)	6U	482	123	133	16	20	
AA-EDP06U19-15KVA-ATS-A-S1	19" Rack Mount - 15 kVA Rated Power ATS MODULE (4 x 63 A I-II Coil Operated ATS , 3 x 40 A - C Type - 3P MCB - 10 kA) (Main Power Supply - Residual Current Device - Precision A/C - UPS Power Supply - UPS Return Line - PDU Power Supply - Spare Circuit Breaker)	6U	482	123	133	16	20	
AA-EDP06U19-20KVA-ATS-A-S1	19" Rack Mount - 20 kVA Rated Power ATS MODULE (4 x 63 A I-II Coil Operated ATS , 3 x 40 A - C Type - 3P MCB - 10 kA) (Main Power Supply - Residual Current Device - Precision A/C - UPS Power Supply - UPS Return Line - PDU Power Supply - Spare Circuit Breaker)	6U	482	123	133	16	20	
AA-EDP06U19-30KVA-ATS-A-S1	19" Rack Mount - 30 kVA Rated Power ATS MODULE (4 x 63 A I-II Coil Operated ATS , 3 x 40 A - C Type - 3P MCB - 10 kA) (Main Power Supply - Residual Current Device - Precision A/C - UPS Power Supply - UPS Return Line - PDU Power Supply - Spare Circuit Breaker)	6U	482	123	133	16	20	
AA-EDP06U19-40KVA-ATS-A-S1	19" Rack Mount - 40 kVA Rated Power ATS MODULE (4 x 63 A I-II Coil Operated ATS , 3 x 40 A - C Type - 3P MCB - 10 kA) (Main Power Supply - Residual Current Device - Precision A/C - UPS Power Supply - UPS Return Line - PDU Power Supply - Spare Circuit Breaker)	6U	482	123	133	16	20	

POWER DISTRIBUTION UNITS

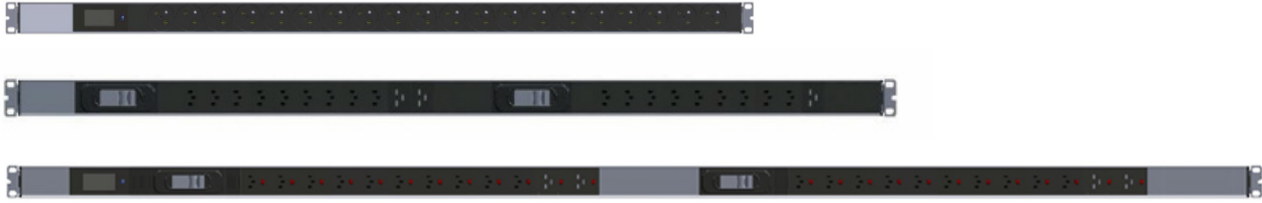

Power Distribution Units (PDUs) provide reliable and straightforward electrical power distribution for IT and data center environments. Thanks to their multi-outlet design, they allow multiple devices to be easily and safely connected to a single power source. Vertical PDUs are typically preferred for standard application scenarios where advanced features are not required, offering a cost-effective and practical solution for everyday power distribution needs. Their simple structure and compatibility with standard racks make them an ideal choice for efficient and organized power management.

POWER DISTRIBUTION UNITS	
Product Code	Product Description
AA-PRZ36U-16(8+8)C13-4C19-AL-VA-2XSG	36U VERTICAL PDU, 16 x IEC320 C13, 4 x IEC320 C19, INTEGRATED AMMETER, 2 x 16 A CB, 250 V AC WITH RATED POWER 8.000 W, 3 m LONG POWER CABLE with 3 x 6 mm ² , IEC60309 32 A (2P+E) CEE PLUG
AA-PRZ36U-16(8+8)C13-4C19-AL-2XSG	36U VERTICAL PDU, 16 x IEC320 C13, 4 x IEC320 C19, 2 x 16 A CB, 250 V AC WITH RATED POWER 8.000 W, 3 m LONG POWER CABLE with 3 x 6 mm ² , IEC 60309 32 A (2P+E) CEE PLUG
AA-PRZ42U-20(10+10)C13-4C19-AL-VA-2XSG	42U VERTICAL PDU, 20 x IEC320 C13, 4 x IEC320 C19, INTEGRATED AMMETER, 2 x 16 A CB, 250 V AC WITH RATED POWER 8.000 W, 3 m LONG POWER CABLE with 3 x 6 mm ² , IEC60309 32 A (2P+E) CEE PLUG
AA-PRZ42U-20(10+10)C13-4C19-AL-2XSG	42U VERTICAL PDU, 20 x IEC320 C13, 4 x IEC320 C19, 2 x 16 A CB, 250 V AC WITH RATED POWER 8.000 W, 3 m LONG POWER CABLE with 3 x 6 mm ² , IEC60309 32 A (2P+E) CEE PLUG
AA-PRZ42U-24(12+12)C13-6C19-AL-VA-2XSG	42U VERTICAL PDU, 24 x IEC320 C13, 4 x IEC320 C19, INTEGRATED AMMETER, 2 x 16 A CB, 250 V AC WITH RATED POWER 8.000 W, 3 m LONG POWER CABLE with 3 x 6 mm ² , IEC60309 32 A (2P+E) CEE PLUG
AA-PRZ42U-24(12+12)C13-6C19-AL-2XSG	42U VERTICAL PDU, 20 x IEC320 C13, 4 x IEC320 C19, 2 x 16 A CB, 250 V AC WITH RATED POWER 8.000 W, 3 m LONG POWER CABLE with 3 x 6 mm ² , IEC60309 32 A (2P+E) CEE PLUG
AA-PRZ36U-16S(8+8)-AL-VA-2XSG	36U VERTICAL PDU, 16(8+8) x SCHUKO, INTEGRATED AMMETER, 2 x 16 A CB, 2 m LONG H05VV-F POWER CABLE with 3 x 4 mm ² , IEC60309 32 A (2P+E) CEE PLUG
AA-PRZ36U-16S(8+8)-AL-2XSG	36U VERTICAL PDU, 16(8+8) x SCHUKO, 2 x 16 A CB, 2 m LONG H05VV-F POWER CABLE with 3 x 4 mm ² , IEC 60309 32 A (2P+E) CEE PLUG
AA-PRZ42U-20S(10+10)-AL-VA-2XSG	42U VERTICAL PDU, 20(10+10) x SCHUKO, INTEGRATED AMMETER, 2 x 16 A CB, 2 m LONG H05VV-F POWER CABLE with 3 x 4 mm ² , IEC60309 32 A (2P+E) CEE PLUG
AA-PRZ42U-20S(10+10)-AL-2XSG	42U VERTICAL PDU, 20(10+10) x SCHUKO, 2 x 16 A CB, 2 m LONG H05VV-F POWER CABLE with 3 x 4 mm ² , IEC 60309 32 A (2P+E) CEE PLUG
AA-PRZ42U-24S(12+12)-AL-VA-2XSG	42U VERTICAL PDU, 24(12+12) x SCHUKO, INTEGRATED AMMETER, 2 x 16 A CB, 2 m LONG H05VV-F POWER CABLE with 3 x 4 mm ² , IEC60309 32 A (2P+E) CEE PLUG
AA-PRZ42U-24S(12+12)-AL-2XSG	42U VERTICAL PDU, 24(12+12) x SCHUKO, 2 x 16 A CB, 2 m LONG H05VV-F POWER CABLE with 3 x 4 mm ² , IEC 60309 32 A (2P+E) CEE PLUG
AA-PRZ47U-20(10+10)C13-4C19-AL-VA-2XSG	47U VERTICAL PDU, 20 x IEC320 C13, 4 x IEC320 C19, INTEGRATED AMMETER, 2 x 16 A CB, 250 V AC WITH RATED POWER 8.000 W, 3 m LONG POWER CABLE with 3 x 6 mm ² , IEC60309 32 A (2P+E) CEE PLUG
AA-PRZ47U-20(10+10)C13-4C19-AL-2XSG	47U VERTICAL PDU, 20 x IEC320 C13, 4 x IEC320 C19, 2 x 16 A CB, 250 V AC WITH RATED POWER 8.000 W, 3 m LONG POWER CABLE with 3 x 6 mm ² , IEC60309 32 A (2P+E) CEE PLUG
AA-PRZ47U-24(12+12)C13-6C19-AL-VA-2XSG	47U VERTICAL PDU, 24 x IEC320 C13, 4 x IEC320 C19, INTEGRATED AMMETER, 2 x 16 A CB, 250 V AC WITH RATED POWER 8.000 W, 3 m LONG POWER CABLE with 3 x 6 mm ² , IEC60309 32 A (2P+E) CEE PLUG
AA-PRZ47U-24(12+12)C13-6C19-AL-2XSG	47U VERTICAL PDU, 24 x IEC320 C13, 4 x IEC320 C19, 2 x 16 A CB, 250 V AC WITH RATED POWER 8.000 W, 3 m LONG POWER CABLE with 3 x 6 mm ² , IEC60309 32 A (2P+E) CEE PLUG

SMART POWER DISTRIBUTION UNITS



Smart PDU measures electrical parameters for each phase. The integrated display shows the measured values and the status of the PDU.

Additional external sensors (temperature, humidity, and air pressure) can be connected to the communication interface.

SMART POWER DISTRIBUTION UNITS	
Product Code	Product Description
AA-SMART-PDU-0U-16C13X4C19-AL-RCM-SG	METERED VERTICAL PDU (INPUT : 230 V, 1 x 16 A ; OUTPUT : 16 x IEC320 C13, 4 x IEC320 C19 ; RESIDUAL CURRENT METERING ; W45 x D45 x H950 mm)
AA-SMART-PDU-0U-16C13X4C19-AL-SG	MONITORED VERTICAL PDU (INPUT : 230 V, 1 x 16 A ; OUTPUT : 16 x IEC320 C13, 4 x IEC320 C19 ; W45 x D45 x H950 mm)
AA-SMART-PDU-01U19-12C13-RCM-SG	1U – 19" RACK MOUNT SWITCHED & OUTLET METERED PDU (INPUT : 230 V, 1 x 16 A ; OUTPUT : 12 x IEC320 C13 ; INTEGRATED OVERVOLTAGE PROTECTION ; W439 x D178 x H44 mm)
AA-IPPRZ36U-16(8+8)C13-4C19-AL-2XSG	IP PDU 36U 16XIEC320 C13+ 4xIEC320 C19 SOCKET A 2x16A INSURANCE 8000WATT 250V AC 3x6mm ² 3 METER CABLE IEC60309 PLUG 32A 2P+E CEE NORM
AA-IPPRZ42U-20(10+10)C13-4C19-AL-2XSG	IP PDU 42U 20XIEC320 C13+ 4xIEC320 C19 SOCKET A 2x16A INSURANCE 8000WATT 250V AC 3x6mm ² 3 METER CABLE IEC60309 PLUG 32A 2P+E CEE NORM W
AA-IPPRZ42U-24(10+10)C13-6C19-AL-2XSG	IP PDU 42U 20XIEC320 C13+ 4xIEC320 C19 SOCKET A 2x16A INSURANCE 8000WATT 250V AC 3x6mm ² 3 METER CABLE IEC60309 PLUG 32A 2P+E CEE NORM
AA-IPPRZ47U-20(10+10)C13-4C19-AL-2XSG	IP PDU 47U 20XIEC320 C13+ 4xIEC320 C19 SOCKET A 2x16A INSURANCE 8000WATT 250V AC 3x6mm ² 3 METER CABLE IEC60309 PLUG 32A 2P+E CEE NORM
AA-IPPRZ47U-24(10+10)C13-6C19-AL-2XSG	IP PDU 47U 20XIEC320 C13+ 4xIEC320 C19 SOCKET A 2x16A INSURANCE 8000WATT 250V AC 3x6mm ² 3 METER CABLE IEC60309 PLUG 32A 2P+E CEE NORM

FIRE EXTINGUISHING MODULES

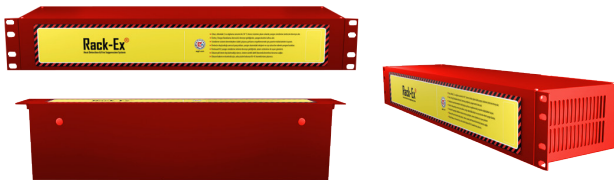

Our compact fire suppression system operates independently without the need for an external power supply and occupies only 2U of rack space inside the cabinet, ensuring maximum space efficiency. When required, dry contact outputs can be provided for integration with external alarm and monitoring systems. The actuator unit includes a 3V Li-ion battery, offering a service life of up to 5 years.

Battery replacement is recommended to be carried out by authorized technical staff. The aerosol fire suppressing agent is UL certified and approved by EPA and SNAP, making it suitable for use in occupied environments. It is non-damaging to electronic equipment and leaves no harmful residue after discharge. The aerosol unit has a shelf life of up to 15 years. The actuator unit is CE, RoHS and UL certified, ensuring compliance with international safety standards.

This system consists of a NOVEC™ 1230 clean agent storage cylinder, a discharge valve, and a special polymer-based distribution tube with engineered rupture points. The cylinder is typically installed in the side compartment of the cabinet or, upon request, in the rear technical section.

When the temperature inside the cabinet reaches 120 °C, the specially designed outlets on the distribution tube rupture, allowing the NOVEC™ 1230 extinguishing agent to be released rapidly and evenly into the protected volume.

NOVEC™ 1230 clean agent is selected for its environmentally friendly properties, as it has zero ozone depletion potential and minimal global warming impact. The system is available with LPCB approval for protected volumes up to 2 m³, ensuring reliable and certified fire protection for critical IT infrastructure.



FIRE EXTINGUISHING SYSTEMS	
Product Code	Product Description
AA-MFS-RACK-EX-2M	2U - 19" RACK MOUNTABLE THERMAL DETECTION AND 2 m ³ FIRE EXTINGUISHING SYSTEM (AEROSOL)
AG-MFS-NOVEC	NOVEC TUBING HOSE AND AEROSOL TANK (2 KG)

GROUNDING SETS



4 grounding cables 4mm diameter Yellow/Green, 40cm length, used for main grounding and potential equalisation.

GROUNDING SETS						
Product Code	Product Description	Width (w) (mm)	Depth (D) (mm)	Height(H) (mm)	Weight (Net) (kg)	Weight (Gross) (kg)
AA-TPR-001-A-CU	220MM BUSBAR GROUNDING SET, 6 GROUNDING POINTS, 4X2.5MM DIAMETER X 40CM LENGTH YELLOW/GREEN CABLE, FOR POTENTIAL EQUALIZATION OF BASIC CABINET CHASSIS AND PANELS.	-	-	-	0,2	0,2
AA-TPR-002-A-CU	780MM LONG VERTICAL MOUNTING TPR SET, 2 PCS 23X2=46 CONNECTION TPR POINTS, 4 PCS 2.5MM DIAMETER X 40CM YELLOW/GREEN CABLE.	25	25	780	1,5	1,7
AA-TPR-012-A-CU-XX-YY	1U 19INCH 400MM GROUNDING SET WITH BARALI KAPAM PANEL, 12 GROUNDING POINTS, 4 PCS X 2.5MM DIAMETER X 40CM LENGTH YELLOW/GREEN CABLE, FOR POTENTIAL EQUALIZATION OF BASIC CABINET CHASSIS AND PANELS.	482	30	45	0,7	0,9

XX = Colour Code, B1 White RAL 7035, S1 Black RAL 9005, during order please specify the colour choice.
YY = M1 for pre-assembled, D1 for flat pack.

SENSORED LIGHTING MODULE



19" 1U, turning function up/down, automatically operating once door is open, closing once door is closed or no movement detected in 60 seconds.

SENSORED LIGHTING MODULE				
Product Code	Product Description	Width (w) (mm)	Depth (D) (mm)	Height(H) (mm)
AA-AYD01U19-A-PS	LIGHTING MODULE 1U 19", WITH DOOR SWITCH -AUTOMATICALLY LIGHTS UP WHEN DOORS ARE OPENED, LED LIGHTING, WITH ROTATION FUNCTION	482	35	44
AA-AYD0T-B	MAGNETIC LED LIGHTING MODULE WHITE	22	20	270
AA-AYD0T-B-OT-SW	STANDARD OUTDOOR MAGNETIC LED LIGHTING MODULE + DOOR SWITCH 220 VOLT WHITE	22	20	270
AA-AYD0T-OS-SW	FIELD PANEL MAGNETIC LED LIGHTING MODULE + DOOR SWITCH 220 VOLT WHITE	22	20	270
AA-AYD01U19-A-PS	01U 19 INCH, DOOR SWITCH, FREEZE FUNCTION, LED LIGHTING MODULE (9005 BLACK)	45	56	520
AA-AYD01U19-A-PS-HTM	0.5U 19 INCH MOTION SENSOR SINGLE COLOR LED LIGHTING MODULE WITH MAGNETIC HOLDER	25	35	485

XX = Colour Code, B1 White RAL 7035, S1 Black RAL 9005, during order please specify the colour choice.
YY = M1 for pre-assembled, D1 for flat pack.

TOOLLESS TYPE BLANK PANELS

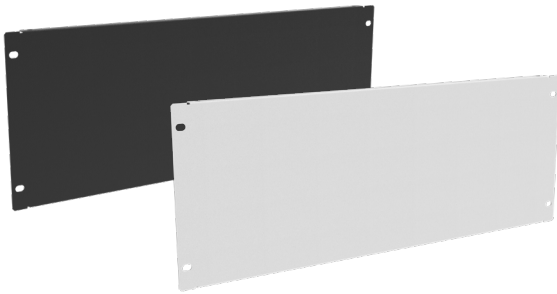

For Empty or Spare U locations in Network and Storage applications, the products could be used for closing and giving a good visual performance to cabinet. In Hot or cold air flow applications, the blanking panels could be used for directing the cold or hot air through. Sizes are various between 1U to 6U in 19" width size. Solid metal toolless model, with special turning clips by hand toolless application can be performed. From Steel Material with 2 bends extra strength given. Supply in RAL 9005 Black and RAL 7035 Light Grey colors

TOOLLESS TYPE BLANK PANELS

Product Code	Product Description	Width (W) (mm)	Depth (D) (mm)	Height(H) (mm)	Weight (Net) (kg)	Weight (Gross) (kg)
AA-KPN01U19-A-XX-YY	1U 19" Blank Panel Toolless	482	12	44	0,26	0,3
AA-KPN02U19-A-XX-YY	2U 19" Blank Panel Toolless	482	12	88	0,43	0,51
AA-KPN03U19-A-XX-YY	3U 19" Blank Panel Toolless	482	12	132	0,6	0,67
AA-KPN04U19-A-XX-YY	4U 19" Blank Panel Toolless	482	12	176	0,77	0,91
AA-KPN05U19-A-XX-YY	5U 19" Blank Panel Toolless	482	12	220	0,93	1,08
AA-KPN06U19-A-XX-YY	6U 19" Blank Panel Toolless	482	12	264	1,1	1,29

XX = Colour Code, B1 White RAL 7035, S1 Black RAL 9005, during order please specify the colour choice.
YY = M1 for pre-assembled, D1 for flat pack.

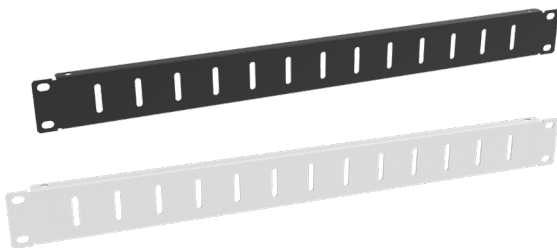

In Network and Storage applications, it is used in cases where cold/hot air passages are allowed in order to correct the appearance by closing the U dimensions where no device is installed, left empty or spare. 19" Closed Type Screw Mounted Closure Panels in sizes from 1U to 6 U are offered as conventional products. Slotted closure panels made of metal with 2 bends are supplied in RAL 9005 Black and RAL 7035 Light Gray Colors.

BLANK PANELS WITH SLOTH

Product Code	Product Description	Width (W) (mm)	Depth (D) (mm)	Height(H) (mm)	Weight (Net) (kg)	Weight (Gross) (kg)
01U19-A-XX-YY	1U 19" Blank Panels with Sloths	482	12	44	0,26	0,3
AA-SKP02U19-A-XX-YY	2U 19" Blank Panels with Sloths	482	12	88	0,43	0,51
AA-SKP03U19-A-XX-YY	3U 19" Blank Panels with Sloths	482	12	132	0,6	0,67
AA-SKP04U19-A-XX-YY	4U 19" Blank Panels with Sloths	482	12	176	0,77	0,91
AA-SKP05U19-A-XX-YY	5U 19" Blank Panels with Sloths	482	12	220	0,93	1,08
AA-SKP06U19-A-XX-YY	6U 19" Blank Panels with Sloths	482	12	264	1,1	1,29

XX = Colour Code, B1 White RAL 7035, S1 Black RAL 9005, during order please specify the colour choice.
YY = M1 for pre-assembled, D1 for flat pack.

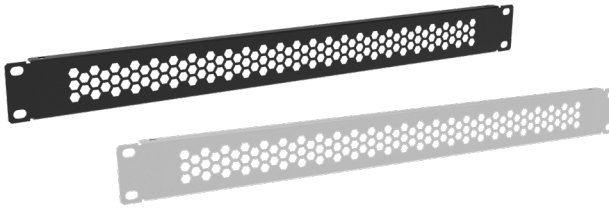

In Network and Storage applications, it is used in cases where cold/hot air passages are allowed in order to correct the decorative appearance by closing the U dimensions where no device is installed, left empty or spare. 19" Closed Type Screw Mounted Closure Panels in sizes from 1U to 6 U are offered as conventional products. Honeycomb perforated discharge closure panels made of metal with 2 bends are supplied in RAL 9005 Black and RAL 7035 Light Gray Colors.

HONEYCOMB PERFORATED BLANK PANELS						
Product Code	Product Description	Width (w) (mm)	Depth (D) (mm)	Height(h) (mm)	Weight (Net) (kg)	Weight (Gross) (kg)
AA-PKP01U19-A-XX-YY	1U 19" Honeycomb Perforated Blank Panels	482	12	44	0,26	0,3
AA-PKP02U19-A-XX-YY	2U 19" Honeycomb Perforated Blank Panels	482	12	88	0,46	0,51
AA-PKP03U19-A-XX-YY	3U 19" Honeycomb Perforated Blank Panels	482	12	132	0,58	0,67
AA-PKP04U19-A-XX-YY	4U 19" Honeycomb Perforated Blank Panels	482	12	176	0,79	0,91
AA-PKP05U19-A-XX-YY	5U 19" Honeycomb Perforated Blank Panels	482	12	220	0,97	1,08
AA-PKP06U19-A-XX-YY	6U 19" Honeycomb Perforated Blank Panels	482	12	264	1,15	1,29

XX = Colour Code, B1 White RAL 7035, S1 Black RAL 9005, during order please specify the colour choice.
YY = M1 for pre-assembled, D1 for flat pack.

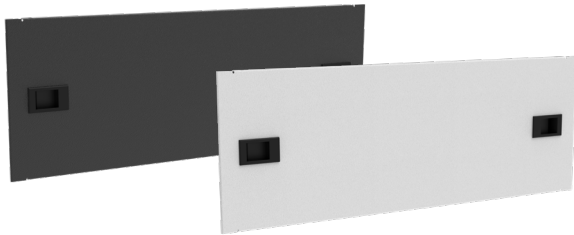

In Network and Storage applications, it is used as a stopper and diverter in cold / hot air passages and to correct the appearance by closing the U dimensions where no device is installed, left empty or spare. 19" Closed Type Tool-Free Removable Closure Panels in sizes from 1U to 6 U are offered as conventional products. Closure panels made of metal with 2 bends are supplied in RAL 9005 Black and RAL 7035 Light Gray Colors.

TOOL FREE BLANK PANELS						
Product Code	Product Description	Width (w) (mm)	Depth (D) (mm)	Height(h) (mm)	Weight (Net) (kg)	Weight (Gross) (kg)
AA-KPN-TBP-01U19-B-XX-YY	1U 19" Tool Free Blank Panels Sliding Lock	482	12	44	0,28	0,3
AA-KPN-TBP-02U19-B-XX-YY	2U 19" Tool Free Blank Panels Sliding Lock	482	12	88	0,46	0,51
AA-KPN-TBP-03U19-B-XX-YY	3U 19" Tool Free Blank Panels Sliding Lock	482	12	132	0,64	0,67
AA-KPN-TBP-04U19-B-XX-YY	4U 19" Tool Free Blank Panels Sliding Lock	482	12	176	0,81	0,91
AA-KPN-TBP-05U19-B-XX-YY	5U 19" Tool Free Blank Panels Sliding Lock	482	12	220	0,99	1,08
AA-KPN-TBP-06U19-B-XX-YY	6U 19" Tool Free Blank Panels Sliding Lock	482	12	264	1,17	1,29

XX = Colour Code, B1 White RAL 7035, S1 Black RAL 9005, during order please specify the colour choice.
YY = M1 for pre-assembled, D1 for flat pack.

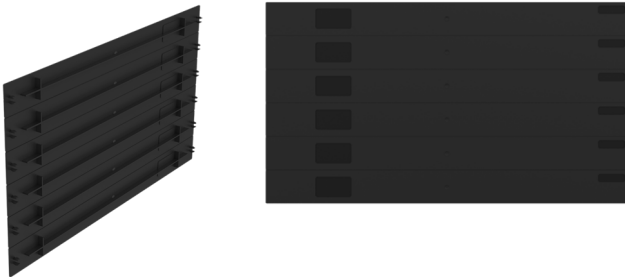

In Network and Storage applications, it is used as a stopper and diverter in cold / hot air passages and to correct the appearance by closing the U dimensions where no device is installed, left empty or spare. 19" Closed Type Tool-Free Removable Closure Panels in sizes from 1U to 6 U are offered as conventional products. Closure panels made of metal with 2 bends are supplied in RAL 9005 Black and RAL 7035 Light Gray Colors.

BREAKABLE BLANK PANEL						
Product Code	Product Description	Width (w) (mm)	Depth (D) (mm)	Height(h) (mm)	Weight (Net) (kg)	Weight (Gross) (kg)
AA-KPN06U19-PS-XX-YY	6U 19" FLAT TOOL-FREE PLASTIC 1U BREAKABLE BLANK PANEL	482	12	266,7	0,36	0,46

VERTICAL CABLE TRAYS

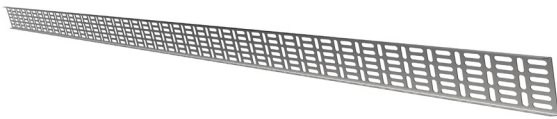

The Vertical Cable Trays are for inserting cable bundles to cabinet and to carry them into the final connection point, W=100mm sized cable trays are vertically used aligning with the cable entry openings on cabinet. The cables should run on the cable trays where the cables tire-up to the matching slot holes on the cable tray. From Steel Material with 2 bends, Dx51D.

VERTICAL CABLE TRAYS

Product Code	Product Description	Width (w) (mm)	Depth (D) (mm)	Height(H) (mm)	Weight (Net) (kg)	Weight (Gross) (kg)
AA-KKN12U10-A-GV	12U CABLE TRAY DX51D+ZN275 GALVANIZED SHEET METAL W=100MM	100	10	526	0,37	0,41
AA-KKN16U10-A-GV	16U CABLE TRAY DX51D+ZN275 GALVANIZED SHEET METAL W=100MM	100	10	704	0,42	0,48
AA-KKN20U10-A-GV	20U CABLE TRAY DX51D+ZN275 GALVANIZED SHEET METAL W=100MM	100	10	882	0,53	0,60
AA-KKN22U10-A-GV	22U CABLE TRAY DX51D+ZN275 GALVANIZED SHEET METAL W=100MM	100	10	971	0,59	0,68
AA-KKN26U10-A-GV	26U CABLE TRAY DX51D+ZN275 GALVANIZED SHEET METAL W=100MM	100	10	1149	0,64	0,71
AA-KKN32U10-A-GV	32U CABLE TRAY DX51D+ZN275 GALVANIZED SHEET METAL W=100MM	100	10	1415,5	0,80	0,88
AA-KKN36U10-A-GV	36U CABLE TRAY DX51D+ZN275 GALVANIZED SHEET METAL W=100MM	100	10	1593,3	0,90	1,01
AA-KKN42U10-A-GV	42U CABLE TRAY DX51D+ZN275 GALVANIZED SHEET METAL W=100MM	100	10	1860	1,05	1,10
AA-KKN47U10-A-GV	47U CABLE TRAY DX51D+ZN275 GALVANIZED SHEET METALW=100MM	100	10	2082	1,2	1,19

XX = Colour Code, B1 White RAL 7035, S1 Black RAL 9005, during order please specify the colour choice.
YY = M1 for pre-assembled, D1 for flat pack.

Vertical Cable managers, for use of carrying the cables into the final connection point. Cable Manager sizes are W=95mm D=82mm. maximum openings for cable management are available due to wire mesh structure. Designed for keeping all kind of patch cables, data cables and electrical cables due to large internal volume. Longitudinally assemble to 19" mounting rails and cable holes are available.



VERTICAL CABLE MANAGEMENT PANELS FREE STANDING TYPE

Product Code	Product Description	Width (w) (mm)	Depth (D) (mm)	Height(H) (mm)	Weight (Net) (kg)	Weight (Gross) (kg)
VG-ORS22U-A-XX-YY	22U Wire Mesh Cable Management panel set left/right	97	97	996	3,55	3,7
VG-ORS26U-A-XX-YY	26U Wire Mesh Cable Management panel set left/right	97	97	1175	4,1	4,4
VG-ORS32U-A-XX-YY	32U Wire Mesh Cable Management panel set left/right	97	97	1440	4,9	5,3
VG-ORS36U-A-XX-YY	36U Wire Mesh Cable Management panel set left/right	97	97	1620	5,4	5,8
VG-ORS42U-A-XX-YY	42U Wire Mesh Cable Management panel set left/right	97	97	1885	6,2	6,6
VG-ORS47U-A-XX-YY	47U Wire Mesh Cable Management panel set left/right	97	97	2110	7,5	8
SR-ORS22U-A-XX-YY	22U Wire Mesh Cable Management panel set left/right	97	97	996	3,55	3,7
SR-ORS26U-A-XX-YY	26U Wire Mesh Cable Management panel set left/right	97	97	1175	4,1	4,4
SR-ORS32U-A-XX-YY	32U Wire Mesh Cable Management panel set left/right	97	97	1440	4,9	5,3
SR-ORS36U-A-XX-YY	36U Wire Mesh Cable Management panel set left/right	97	97	1620	5,4	5,8
SR-ORS42U-A-XX-YY	42U Wire Mesh Cable Management panel set left/right	97	97	1885	6,2	6,6
SR-ORS47U-A-XX-YY	47U Wire Mesh Cable Management panel set left/right	97	97	2110	7,5	8

XX = Colour Code, B1 White RAL 7035, S1 Black RAL 9005, during order please specify the colour choice.
YY = M1 for pre-assembled, D1 for flat pack.



Vertical Cable Arrangement Class, W=106mm D=109mm finger type cable trays for the management and transfer of cables taken into the cabinet. Maximum cable passage openings are available to allow dense cabling. Thanks to its large internal volume, it is designed to store all kinds of patch cables, data cables and electrical cables. Along the 19" device uprights, it is connected to the sides of the device uprights and cable pass-through openings are available.

VERTICAL CABLE ORGANIZER PANELS VERTICAL TYPE

Product Code	Product Description	Width (w) (mm)	Depth (D) (mm)	Height(H) (mm)	Weight (Net) (kg)	Weight (Gross) (kg)
VG-FORS22U-A-XX-YY	22U VERTICAL FINGER ORGANIZER SET RIGHT/LEFT	106	109	982	4,2	4,6
VG-FORS26U-A-XX-YY	26U VERTICAL FINGER ORGANIZER SET RIGHT/LEFT	106	109	1161	5	5,4
VG-FORS32U-A-XX-YY	32U VERTICAL FINGER ORGANIZER SET RIGHT/LEFT	106	109	1426	6	6,4
VG-FORS36U-A-XX-YY	36U VERTICAL FINGER ORGANIZER SET RIGHT/LEFT	106	109	1606	6,9	7,3
VG-FORS42U-A-XX-YY	42U VERTICAL FINGER ORGANIZER SET RIGHT/LEFT	106	109	1871	8	8,4
VG-FORS47U-A-XX-YY	47U VERTICAL FINGER ORGANIZER SET RIGHT/LEFT	106	109	2096	9	9,4
SR-FORS22U-A-XX-YY	22U VERTICAL FINGER ORGANIZER SET RIGHT/LEFT	106	109	982	4,2	4,6
SR-FORS26U-A-XX-YY	26U VERTICAL FINGER ORGANIZER SET RIGHT/LEFT	106	109	1161	5	5,4
SR-FORS32U-A-XX-YY	32U VERTICAL FINGER ORGANIZER SET RIGHT/LEFT	106	109	1426	6	6,4
SR-FORS36U-A-XX-YY	36U VERTICAL FINGER ORGANIZER SET RIGHT/LEFT	106	109	1606	6,9	7,3
SR-FORS42U-A-XX-YY	42U VERTICAL FINGER ORGANIZER SET RIGHT/LEFT	106	109	1871	8	8,4
SR-FORS47U-A-XX-YY	47U VERTICAL FINGER ORGANIZER SET RIGHT/LEFT	106	109	2096	9	9,4

XX = Colour Code, B1 White RAL 7035, S1 Black RAL 9005, during order please specify the colour choice.
YY = M1 for pre-assembled, D1 for flat pack.



Vertical Cable Arrangement Class, W=95mm D=82mm cable trays for the management and transfer of cables taken into the cabinet. Maximum cable passage openings are available to allow dense cabling. Thanks to its large internal volume, it is designed to store all kinds of patch cables, data cables and electrical cables. Along the 19" device uprights, it is connected to the sides of the device uprights and cable pass-through openings are available.

VERTICAL CABLE ORGANIZER PANELS VERTICAL TYPE

Product Code	Product Description	Width (w) (mm)	Depth (D) (mm)	Height(H) (mm)	Weight (Net) (kg)	Weight (Gross) (kg)
VG-ORS22U-A-XX-YY	22U VERTICAL ORGANIZER SET RIGHT/LEFT	97	97	996	3,55	3,7
VG-ORS26U-A-XX-YY	26U VERTICAL ORGANIZER SET RIGHT/LEFT	97	97	1175	4,1	4,4
VG-ORS32U-A-XX-YY	32U VERTICAL ORGANIZER SET RIGHT/LEFT	97	97	1440	4,9	5,3
VG-ORS36U-A-XX-YY	36U VERTICAL ORGANIZER SET RIGHT/LEFT	97	97	1620	5,4	5,8
VG-ORS42U-A-XX-YY	42U VERTICAL ORGANIZER SET RIGHT/LEFT	97	97	1885	6,2	6,6
VG-ORS47U-A-XX-YY	47U VERTICAL ORGANIZER SET RIGHT/LEFT	97	97	2110	7,5	8

XX = Colour Code, B1 White RAL 7035, S1 Black RAL 9005, during order please specify the colour choice.
YY = M1 for pre-assembled, D1 for flat pack.

HORIZONTAL CABLE ORGANIZATION ACCESSORIES

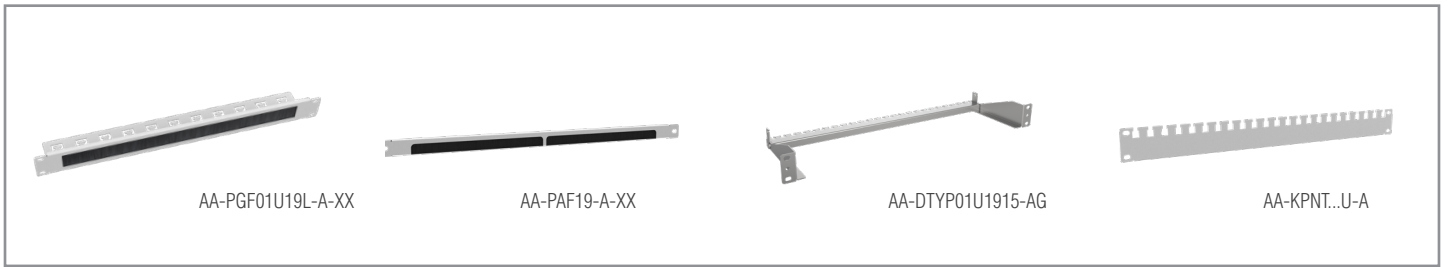
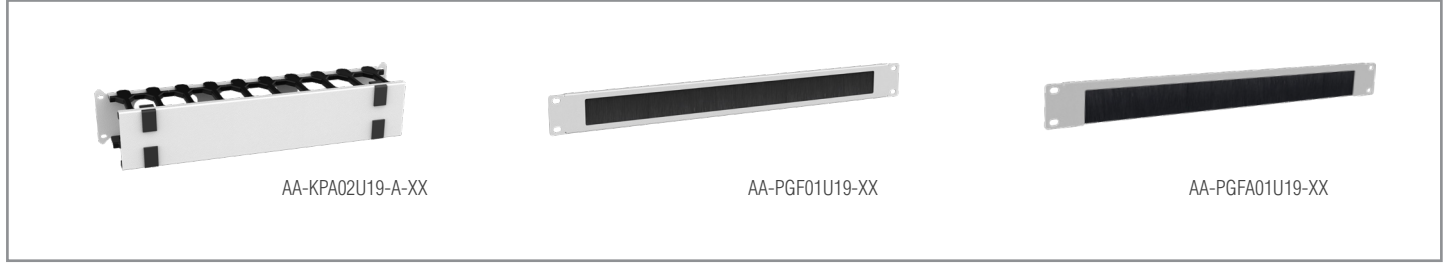
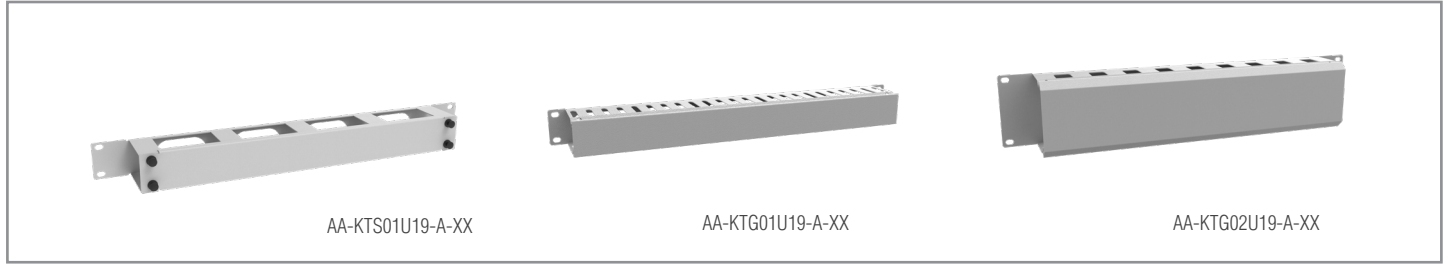

Horizontal Cable Arrangement Class, various accessories for the management and transfer of cables taken into the cabin. 1/2U, 1U, 2U brush, hook, cover types are available. Supplied in RAL 9005 Black and RAL 7035 Light Gray Colors.

HORIZONTAL CABLE ORGANIZATION ACCESSORIES						
Product Code	Product Description	Width (w) (mm)	Depth (D) (mm)	Height(H) (mm)	Weight (Net) (kg)	Weight (Gross) (kg)
AA-KTS01U19-A-XX-YY	1U 19" CABLE ORGANIZATION PANEL, DUCT TYPE WITH REMOVABLE FRONT COVER	482	75	44	0,51	0,55
AA-KTG01U19-A-XX-YY	1U 19" CABLE ORGANIZER PANEL, DUCT TYPE WITH REMOVABLE FRONT COVER WITH CRADLE	482	72	44	0,68	0,72
AA-KTG02U19-A-XX-YY	2U 19" CABLE ORGANIZER PANEL, DUCT TYPE CRADLE WITH REMOVABLE FRONT COVER	482	72	88	1,35	1,47
AA-KPA02U19-A-XX-YY	2U 19" CABLE ORGANIZER PANEL WITH INTEGRATED DUCT TYPE PLASTIC ORGANIZER WITH 2U OPENABLE FRONT COVER	482	165	88	1,54	1,75
AA-PGF01U19-A-XX-YY	1U 19" CABLE ORGANIZATION PANEL PATCHCORD ENTRANCE HALL BRUSH TYPE	482	12	44	0,25	0,29
AA-PGFA01U19-A-XX-YY	1U 19" CABLE ORGANIZATION PANEL PATCHCORD ENTRANCE HALL BRUSH ONE SIDE OPEN TYPE	482	12	44	0,25	0,29
AA-PGF01U19L-A-XX-YY	1U 19" CABLE ORGANIZER PANEL BRUSH TYPE, L TWIST, ORGANIZER WITH REAR PATCHCORD HOLDER	482	112	44	0,58	0,76
AA-PAF19-A-XX-YY	1/2U 19" CABLE ARRANGEMENT PANEL PATCHCORD ENTRANCE HALL, OPEN EDGES BRUSHED TYPE	482	12	22	0,45	0,64
AA-DTYP01U1915-AG-XX-YY	1U 19" D=150MM CABLE CREEP-UP PART	482	150	44	0,4	0,56
AA-KPNT01U-A-XX-YY	1U 19" CABLE TIRE-UP PANEL	482	-	44	0,3	0,46

XX = Colour Code, B1 White RAL 7035, S1 Black RAL 9005, during order please specify the colour choice.
YY = M1 for pre-assembled, D1 for flat pack.

ORGANIZER WITH HOOKS

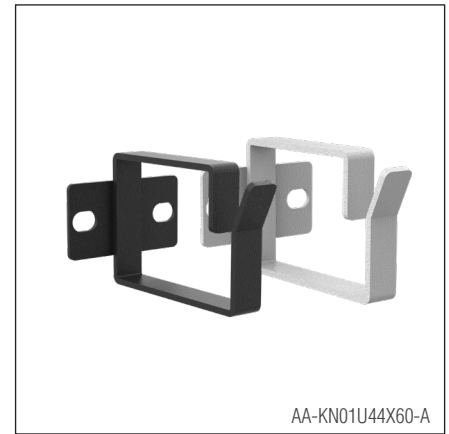
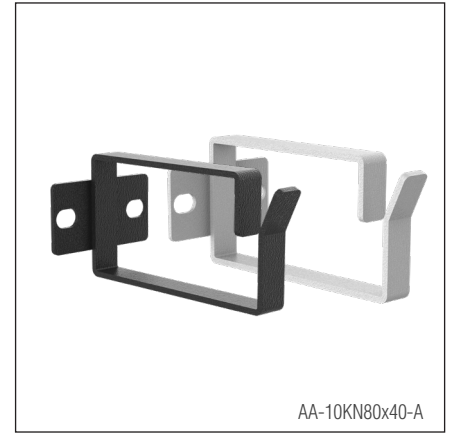
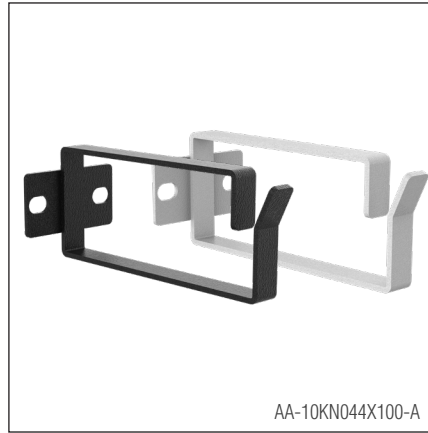

Universal Cable Arrangement hooks compatible with all types of cabinets, They are various accessories for the management and transfer of cables taken into the cabinet. Different size options are available. Supplied in RAL 9005 Black and RAL 7035 Light Gray Colors.

ORGANIZERS WITH HOOKS

Product Code	Product Description	Width (w) (mm)	Depth (D) (mm)	Height(H) (mm)	Weight (Net) (kg)	Weight (Gross) (kg)
AA-10KN01U70X150-A-XX-YY	1U 70X150MM METAL CABLE ORGANIZER HOOK 1 SET 10 PCS	44	70	150	0,76	0,86
AA-10KN044X100-A-XX-YY	1U 44X100MM METAL CABLE ORGANIZER HOOK 1 SET 10 PCS	44	44	100	0,55	0,65
AA-10KN80x40-A-XX-YY	1U 80X40MM METAL CABLE ORGANIZER HOOK 1 SET 10 PCS	44	80	40	0,65	0,75
AA-10KN80x80-A-XX-YY	1U 80X80MM METAL CABLE ORGANIZER HOOK 1 SET 10 PCS	44	80	80	0,77	0,87
AA-10KN80x100-A-XX-YY	1U 80X100MM METAL CABLE ORGANIZER HOOK 1 SET 10 PCS	44	80	100	1,07	1,17
AA-KN01U44X60-A-XX-YY	1U 44X60MM METAL CABLE ORGANIZER HOOK 1 SET 10 PCS	44	44	60	0,59	0,69

XX = Colour Code, B1 White RAL 7035, S1 Black RAL 9005, during order please specify the colour choice.
YY = M1 for pre-assembled, D1 for flat pack.

HOOKED ORGANIZERS

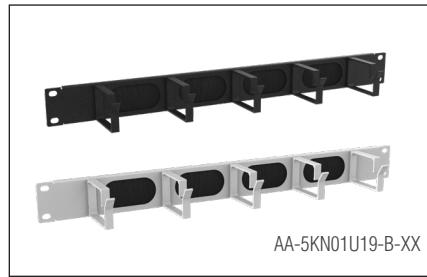
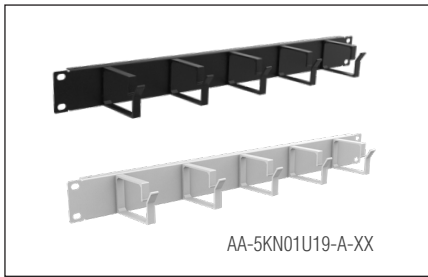

Horizontal Cable Arrangement Panels are various accessories for the management and transfer of cables taken into the cabinet. 1U, 2U hooked, hooked and brushed types are available. Supplied in RAL 9005 Black and RAL 7035 Light Gray Colors.

HORIZONTAL CABLE ORGANIZERS WITH HOOKS

Product Code	Product Description	Width (w) (mm)	Depth (D) (mm)	Height(H) (mm)	Weight (Net) (kg)	Weight (Gross) (kg)
AA-5KN01U19-A-XX-YY	1U 19 INCH A TYPE 5 ALM 44X60 HOOKED ORGANIZER	482	60	44	0,32	0,35
AA-5KN01U19-B-XX-YY	1U 19 INCH B TYPE 5 ALM 44X60 HOOKED ORGANIZER (BRUSH CABLE PASSAGE BETWEEN HOOKS)	482	60	44	0,4	0,43
AA-5KN02U19-A-XX-YY	2U 19 INCH A TYPE 5 ALM 88X60 HOOKED ORGANIZER	482	60	88	1,35	1,47

XX = Colour Code, B1 White RAL 7035, S1 Black RAL 9005, during order please specify the colour choice.
YY = M1 for pre-assembled, D1 for flat pack.

ADAPTORS

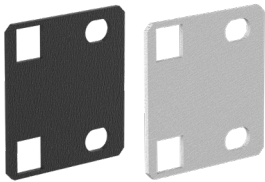

They are apparatus for converting 21" device mounting area to 19". You can contact our sales department for different size options.

ADAPTORS

Product Code	Product Description	Width (w) (mm)	Depth (D) (mm)	Height(H) (mm)	Weight (Net) (kg)	Weight (Gross) (kg)
AA-ADAPT2119-A-XX-YY	21 INCH TO 19 INCH CONVERSION ADAPTER (1SET INCLUDES 2 SETS OF EARS AND 4 SETS OF CAGE NUTS)	44	44	1,5	-	-

XX = Colour Code, B1 White RAL 7035, S1 Black RAL 9005, during order please specify the colour choice.
YY = M1 for pre-assembled, D1 for flat pack.

PDU CONNECTORS

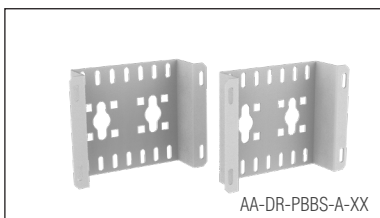

Multi-purpose mounting brackets compatible with all cabinet types, made of metal material, Vertical PDU etc.

PDU CONNECTORS

Product Code	Product Description	Width (w) (mm)	Depth (D) (mm)	Height(H) (mm)	Weight (Net) (kg)	Weight (Gross) (kg)
AA-DR-PBBS-A-XX	PDU CONNECTION CONNECTORS	44	98,5	10	0,06	0,09

XX = Colour Code, B1 White RAL 7035, S1 Black RAL 9005, during order please specify the colour choice.
YY = M1 for pre-assembled, D1 for flat pack.

CABINET JOINT KITS

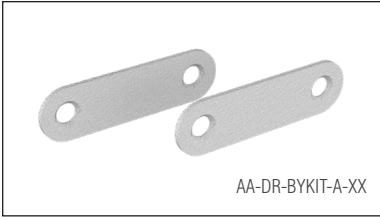

Cabinet joint kit is a mounting solution consisting of metal connection components designed to securely and neatly fix multiple cabinets together, compatible with various cabinet types.

CABINET JOINT KITS						
Product Code	Product Description	Width (w) (mm)	Depth (D) (mm)	Height(H) (mm)	Weight (Net) (kg)	Weight (Gross) (kg)
AA-DR-BYKIT-A-XX	CABINET JOINT KITS	20	1,5	80	0,06	0,09

XX = Colour Code, B1 White RAL 7035, S1 Black RAL 9005, during order please specify the colour choice.
YY = M1 for pre-assembled, D1 for flat pack.

ELECTRICITY DISTRIBUTION MODULES

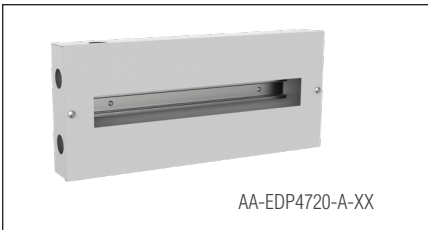
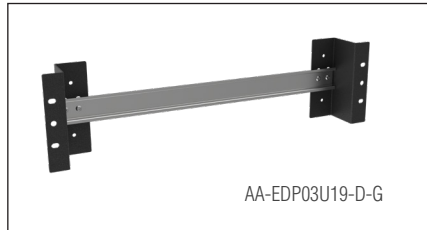
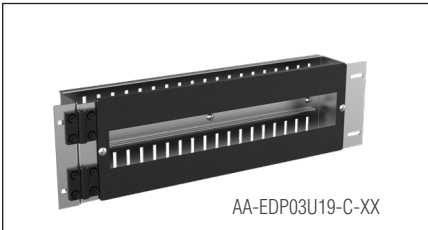
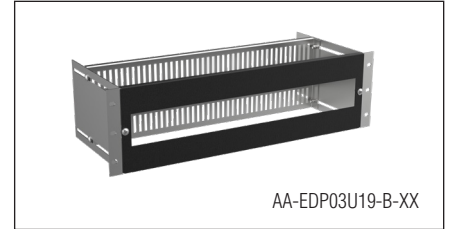
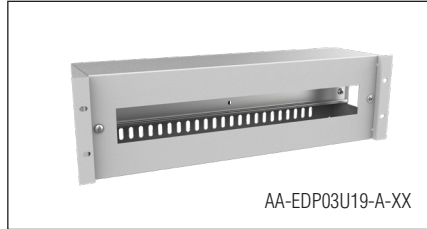
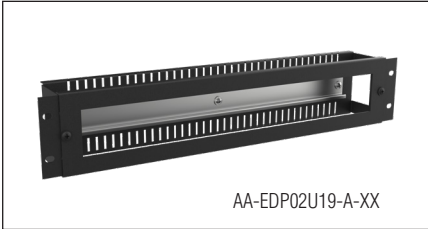

Electrical distribution module; It is a diversified accessory compatible with all 19 cabinets and field panels designed for electrical distribution operations in the cabinet with its metal material, protected with cover / unprotected without cover.

ELECTRICITY DISTRIBUTION MODULES						
Product Code	Product Description	Width (w) (mm)	Depth (D) (mm)	Height(H) (mm)	Weight (Net) (kg)	Weight (Gross) (kg)
AA-EDP02U19-A-XX-YY	2U 19 INCH ELECTRICAL DISTRIBUTION PANEL 22 MODULE CAPACITY	482	70	88	1	1,1
AA-EDP03U19-A-XX-YY	3U 19 INCH ELECTRICAL DISTRIBUTION PANEL WITH 18 MODULE CAPACITY	482	123	133	2,3	2,4
AA-EDP03U19-B-XX-YY	3U 19 INCH MOUNTING DEPTH ADJUSTABLE, MOVABLE ELECTRICAL DISTRIBUTION PANEL 23 MODULE CAPACITY	482	133	133	1,95	2,05
AA-EDP03U19-C-XX-YY	3U 19 INCH HINGED MOVABLE ELECTRICAL DISTRIBUTION PANEL 20 MODULE CAPACITY	482	66	133	1,7	1,8
AA-EDP03U19-D-G-XX-YY	3U 19 INCH OPEN SYSTEM ELECTRICITY DISTRIBUTION PANEL WITH 24 MODULE CAPACITY	482	54,5	126	0,5	0,6
AA-EDP2420-A-XX-YY	W=240 H=185 D=61MM PANEL TYPE ELECTRICAL DISTRIBUTION PANEL 11 MODULE CAPACITY (1AD 200MM OTM RAIL)	240	61	185	0,75	0,8
AA-EDP4720-A-XX-YY	W=470 H=203 D=55MM PANEL TYPE ELECTRICAL DISTRIBUTION PANEL 21 MODULE CAPACITY (1AD 380MM AUTM RAIL)	470	55	203	1,8	1,9

XX = Colour Code, B1 White RAL 7035, S1 Black RAL 9005, during order please specify the colour choice.
YY = M1 for pre-assembled, D1 for flat pack.

FIXED SHELVES

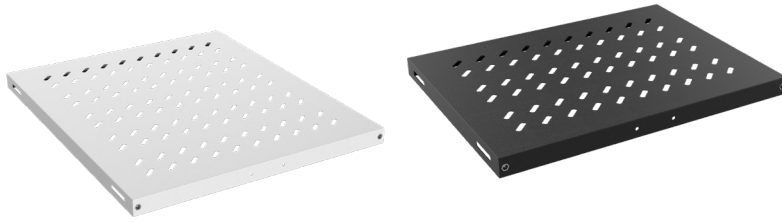

Fixed Shelves, 4 point fixing, Compatible with AGER cabinet. For allowing the convection of heated air inside cabinets, the shelves are structured with ventilation slots. Supply is in RAL 9005 Black and RAL 7035 Light Grey colors. From Steel Material, with high technology bending strengthening accessory, Load capacity 50 kg.

FIXED SHELVES 4 POINT FIXING

Product Code	Product Description	Width (w) (mm)	Depth (D) (mm)	Height (H) (mm)	Weight (Net) (kg)	Weight (Gross) (kg)
AA-SBT60-A-XX-YY	19" FIXED SHELVES, 4 POINTS FIXING, PHYSICAL SHELF DEPTH:370MM D=600MM CABINETS, LOAD CAPACITY 50 KG	482,6	370	30	1,8	2
AA-SBT80-A-XX-YY	19" FIXED SHELVES, 4 POINTS FIXING, PHYSICAL SHELF DEPTH:570MM D=800MM CABINETS, LOAD CAPACITY 50 KG	482,6	570	30	2,5	3
AA-SBT10-A-XX-YY	19" FIXED SHELVES, 4 POINTS FIXING, PHYSICAL SHELF DEPTH:740MM D=1000MM CABINETS, LOAD CAPACITY 50 KG	482,6	770	30	3,5	3,9

XX = Colour Code, B1 White RAL 7035, S1 Black RAL 9005, during order please specify the colour choice.
YY = M1 for pre-assembled, D1 for flat pack.

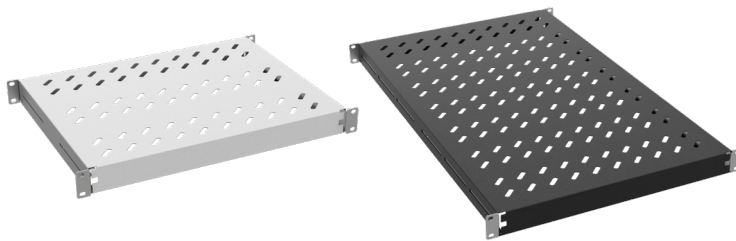

Fixed Shelves, 4 point fixing, Compatible with all brand cabinets. Adjustable brackets at depth. For allowing the convection of heated air inside cabinets, the shelves are structured with ventilation slots. Supply is in RAL 9005 Black and RAL 7035 Light Grey colors. From Steel Material, with high technology bending strengthening accessory, Load capacity 50 kg.

FIXED SHELVES 4 POINT FIXING, UNIVERSAL MODEL

Product Code	Product Description	Width (w) (mm)	Depth (D) (mm)	Height (H) (mm)	Weight (Net) (kg)	Weight (Gross) (kg)
AA-SBT35-C-XX-YY	" FIXED SHELVES, 1U METAL BRACKET, 4 POINT FIXING, PHYSICAL SHELF DEPTH:350MM D=600MM CABINETS, LOAD CAPACITY 50 KG. COMPATIBLE WITH ALL BRAND 19" CABINETS."	482,6	350	44	2	2,4
AA-SBT50-C-XX-YY	" FIXED SHELVES, 1U METAL BRACKET, 4 POINT FIXING, PHYSICAL SHELF DEPTH:500MM D=800MM CABINETS, LOAD CAPACITY 50 KG. COMPATIBLE WITH ALL BRAND 19" CABINETS."	482,6	500	44	3	3,4
AA-SBT10-C-XX-YY	" FIXED SHELVES, 1U METAL BRACKET, 4 POINT FIXING, PHYSICAL SHELF DEPTH:735MM D=800MM CABINETS, LOAD CAPACITY 50 KG. COMPATIBLE WITH ALL BRAND 19" CABINETS."	482,6	735	44	4,2	4,8

XX = Colour Code, B1 White RAL 7035, S1 Black RAL 9005, during order please specify the colour choice.
YY = M1 for pre-assembled, D1 for flat pack.

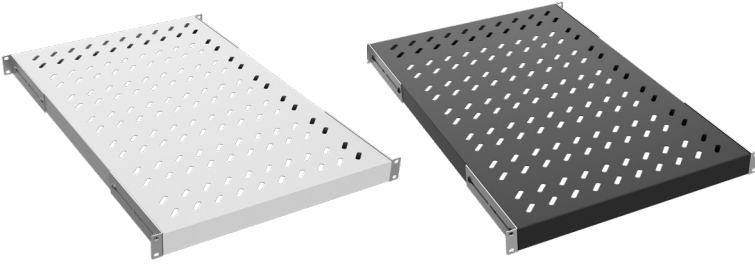

Heavy Duty Fixed Shelves, 4 point fixing, Compatible with AGER cabinets. For allowing the convection of heated air inside cabinets, the shelves are structured with ventilation slots. 1U sized. Supply is in RAL 9005 Black and RAL 7035 Light Grey colors. From Steel Material, with high technology bending strengthening accessory, Load capacity 100 kg.

HEAVY DUTY FIXED SHELVES 4 POINTS FIXING						
Product Code	Product Description	Width (W) (mm)	Depth (D) (mm)	Height (H) (mm)	Weight (Net) (kg)	Weight (Gross) (kg)
AA-ASB10-A-XX-YY	"19" HEAVY DUTY FIXED SHELVES, 1U, 4 POINT FIXING, PHYSICAL SHELF DEPTH :720MM D=1000MM CABINETS, LOAD CAPACITY 100 KG"	482,6	720	44	4,2	4,7

XX = Colour Code, B1 White RAL 7035, S1 Black RAL 9005, during order please specify the colour choice.
YY = M1 for pre-assembled, D1 for flat pack.

SLIDING SHELVES



Sliding Shelves, 4 point fixing, Compatible with all brand cabinets Multivendor. Adjustable brackets at depth. For allowing the convection of heated air inside cabinets, the shelves are structured with ventilationslots. Supply is in RAL 9005 Black and RAL 7035 Light Grey colors. From Steel Material, with high technology bending strengthening accessory, Load capacity 30 kg.

SLIDING SHELVES 4 POINT FIXING, MULTIVENDOR, Compatible With All Brand Cabinets						
Product Code	Product Description	Width (W) (mm)	Depth (D) (mm)	Height (H) (mm)	Weight (Net) (kg)	Weight (Gross) (kg)
AA-HRR60-A-XX-YY	"19" SLIDING SHELVES 4 POINT FIXING, PHYSICAL SHELF DEPTH:370MM D=600MM CABINETS, LOAD CAPACITY 30 KG. COMPATIBLE WITH ALL BRAND 19" CABINETS."	482,6	370	44	2,4	2,7
AA-HRR80-A-XX-YY	"19" SLIDING SHELVES 4 POINT FIXING, PHYSICAL SHELF DEPTH:570MM D=800MM CABINETS, LOAD CAPACITY 30 KG. COMPATIBLE WITH ALL BRAND 19" CABINETS."	482,6	570	44	3,3	3,6
AA-HRR10-A-XX-YY	"19" SLIDING SHELVES 4 POINT FIXING, PHYSICAL SHELF DEPTH:740MM D=800MM CABINETS, LOAD CAPACITY 30 KG. COMPATIBLE WITH ALL BRAND 19" CABINETS."	482,6	740	44	4,6	4,9

XX = Colour Code, B1 White RAL 7035, S1 Black RAL 9005, during order please specify the colour choice.
YY = M1 for pre-assembled, D1 for flat pack.



Heavy Duty Sliding Shelves, 4 point fixing, Compatible with all brand cabinets. For allowing the convection of heated air inside cabinets, the shelves are structured with ventilation slots. 1U sized. Adjustable brackets at depth. With this feature the item can be assembled to any brand cabinet. Supply is in RAL 9005 Black and RAL 7035 Light Grey colors.

From Steel Material, with high technology bending strengthening accessory, Load capacity 50 kg.

HEAVY DUTY SLIDING SHELVES 4 POINT FIXING						
Product Code	Product Description	Width (w) (mm)	Depth (D) (mm)	Height (H) (mm)	Weight (Net) (kg)	Weight (Gross) (kg)
AA-AHR10-A-XX-YY	19" HEAVY DUTY SLIDING SHELVES 4 POINT FIXING, PHYSICAL SHELF DEPTH :720MM D=1000MM CABINETS. LOAD CAPACITY 50 KG, FULL TELESCOPIC.	486	720	44	6,1	6,7
AA-AHR10-AKRO-A-XX-YY	19" HEAVY DUTY SLIDING SHELVES, 1U 19", 4 POINT FIXING, PHYSICAL SHELF DEPTH :720MM D=1000MM CABINETS. LOAD CAPACITY 50 KG, FULL TELESCOPIC. CABLE ORGANISER WITH ACROBAT ARM ATTACHMENT.	482,6	720	44	6,1	6,7

XX = Colour Code, B1 White RAL 7035, S1 Black RAL 9005, during order please specify the colour choice.
YY = M1 for pre-assembled, D1 for flat pack.

RACK MOUNT SHELVES

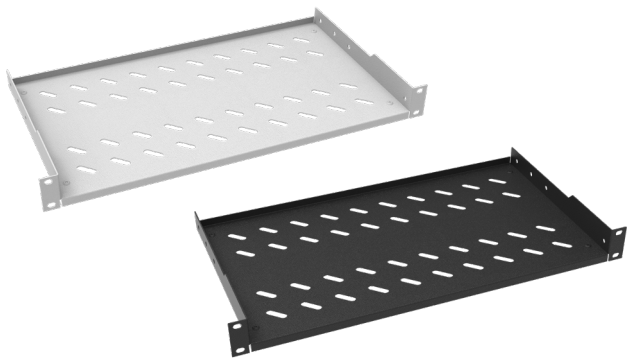

The assembly should be frontal assembly to the equipment mounting rails. For allowing the convection of heated air inside cabinets, the shelves are structured with ventilation slots. Supply is in RAL 9005 Black and RAL 7035 Light Grey colors. From Steel Material, with high technology bending strengthening accessory, Load capacity 30 kg.

RACK MOUNT SHELVES 2 POINT FIXING						
Product Code	Product Description	Width (w) (mm)	Depth (D) (mm)	Height(H) (mm)	Weight (Net) (kg)	Weight (Gross) (kg)
AA-RMR01U20-B-XX-YY	"19" 1U D=200MM RACK MOUNT 2 POINT FIXING SHELVES, LOADING CAPACITY 30 KG"	482,6	200	44	0,9	1,1
AA-RMR01U25-B-XX-YY	"19" 1U D=250MM RACK MOUNT 2 POINT FIXING SHELVES, LOADING CAPACITY 30 KG"	482,6	250	44	1,1	1,3
AA-RMR01U30-B-XX-YY	"19" 1U D=300MM RACK MOUNT 2 POINT FIXING SHELVES, LOADING CAPACITY 30 KG"	482,6	300	44	1,3	1,6
AA-RMR01U35-B-XX-YY	"19" 1U D=350MM RACK MOUNT 2 POINT FIXING SHELVES, LOADING CAPACITY 30 KG"	482,6	350	44	1,5	1,8
AA-RMR01U40-B-XX-YY	"19" 1U D=400MM RACK MOUNT 2 POINT FIXING SHELVES, LOADING CAPACITY 30 KG"	482,6	400	44	1,7	2,1
AA-RMR02U25-B-XX-YY	"19" 2U D=250MM RACK MOUNT 2 POINT FIXING SHELVES, LOADING CAPACITY 30 KG"	482,6	250	88	1,3	1,6
AA-RMR02U30-B-XX-YY	"19" 2U D=300MM RACK MOUNT 2 POINT FIXING SHELVES, LOADING CAPACITY 30 KG"	482,6	300	88	1,7	2
AA-RMR02U35-B-XX-YY	"19" 2U D=350MM RACK MOUNT 2 POINT FIXING SHELVES, LOADING CAPACITY 30 KG"	482,6	350	88	2,1	2,4
AA-RMR02U40-B-XX-YY	"19" 2U D=400MM RACK MOUNT 2 POINT FIXING SHELVES, LOADING CAPACITY 30 KG"	482,6	400	88	2,5	2,8

XX = Colour Code, B1 White RAL 7035, S1 Black RAL 9005, during order please specify the colour choice.
YY = M1 for pre-assembled, D1 for flat pack.



The assembly should be frontal assembly to the equipment mounting rails. It is an accessory that can be mounted from 4 points by means of the Depth Adjustable Side Arms at the back. Ventilation slots are placed in order not to interfere with the ventilation system. It is supplied in RAL 9005 Black and RAL 7035 Light Grey colours. It is an accessory with high strength structured from steel material with bending technology. Carrying capacity is 50 kg.

RACK MOUNT SHELVES 4 POINT FIXING						
Product Code	Product Description	Width (w) (mm)	Depth (D) (mm)	Height(H) (mm)	Weight (Net) (kg)	Weight (Gross) (kg)
AA-RMR01U35-11-B-XX-YY	1U 19" FROM THE FRONT, 1 U 19" REAR MOUNTING AREA, ADJUSTABLE SIDE ARM SYSTEM, D=350MM, 19" IN ALL CABINETS FOR USE, LOADING CAPACITY 50KG	482,6	350	44	2,2	2,6
AA-RMR02U35-21-B-XX-YY	2U 19" FROM THE FRONT, 1 U 19" REAR MOUNTING AREA, ADJUSTABLE SIDE ARM SYSTEM, D=350MM, 19" IN ALL CABINETS FOR USE, LOADING CAPACITY 50KG	482,6	350	88	2,1	2,4
AA-RMR01U45-11-B-XX-YY	1U 19" FROM THE FRONT, 1 U 19" REAR MOUNTING AREA, ADJUSTABLE SIDE ARM SYSTEM, D=450MM, 19" IN ALL CABINETS FOR USE, LOADING CAPACITY 50KG	482,6	450	44	2,4	2,7
AA-RMR02U45-21-B-XX-YY	2U 119" FROM THE FRONT, 1 U 19" REAR MOUNTING AREA, ADJUSTABLE SIDE ARM SYSTEM, D=450MM, 19" IN ALL CABINETS FOR USE, LOADING CAPACITY 50KG	482,6	450	88	2,7	3,1
AA-RMR02U55-21-B-XX-YY	2U 19" FROM THE FRONT, 1 U 19" REAR MOUNTING AREA, ADJUSTABLE SIDE ARM SYSTEM, D=550MM, 19" IN ALL CABINETS FOR USE, LOADING CAPACITY 50KG	482,6	550	88	3,3	3,7
AA-RMR02U65-21-B-XX-YY	2U 19" FROM THE FRONT, 1 U 19" REAR MOUNTING AREA, ADJUSTABLE SIDE ARM SYSTEM, D=650MM, 19" IN ALL CABINETS FOR USE, LOADING CAPACITY 50KG	482,6	650	88	3,5	4

XX = Colour Code, B1 White RAL 7035, S1 Black RAL 9005, during order please specify the colour choice.
YY = M1 for pre-assembled, D1 for flat pack.

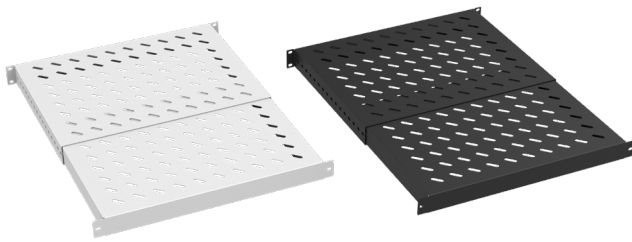

Front and rear connections can be made to the device mounting uprights. Ventilation slots are placed so as not to interfere with the ventilation system. Available in RAL 9005 Black and RAL 7035 Light Grey. It is a high strength accessory made of steel material with bending technology. Carrying capacity is 50 kg.

ADJUSTABLE FIXED SHELVES 6 POINT FIXING						
Product Code	Product Description	Width (w) (mm)	Depth (D) (mm)	Height(H) (mm)	Weight (Net) (kg)	Weight (Gross) (kg)
AA-AHR01U193560-A-XX-YY	19 INCH HEAVY DUTY SLIDING SHELVES 6 POINT FIXING (SHELVES DEPTH MAX=597MM MIN=345,5MM) (CABINET DEPTH 600MM FOR USE.) LOADING CAPACITY 50 KG	482	346	45	2,4	2,7
AA-AHR01U195090-A-XX	19 INCH HEAVY DUTY SLIDING SHELVES 6 POINT FIXING (SHELVES DEPTH MAX=897MM MIN=495,5MM) (CABINET DEPTH 600MM FOR USE.) LOADING CAPACITY 50 KG	482	496	45	3,3	3,6

XX = Colour Code, B1 White RAL 7035, S1 Black RAL 9005, during order please specify the colour choice.
YY = M1 for pre-assembled, D1 for flat pack.

STORAGE DRAWERS

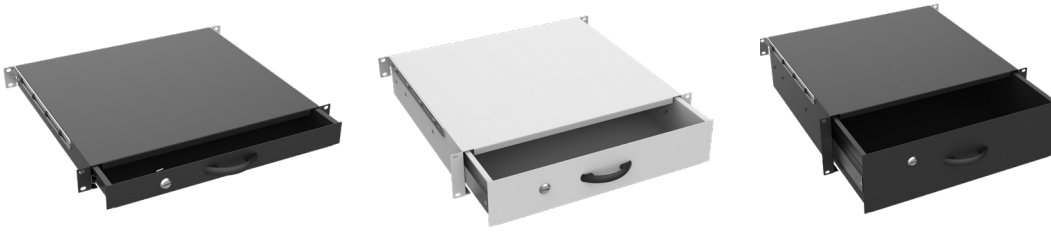

General purpose storage drawers, could house various user manuals, software CDs secure way. Additionally can be integrated with Keyboard. Supply is in RAL 9005 Black and RAL 7035 Light Grey colors. Steel Material is used, with high technology bending strengthening accessory, Load capacity 50 kg.

GENERAL STORAGE DRAWERS

Product Code	Product Description	Width (w) (mm)	Depth (D) (mm)	Height(H) (mm)	Weight (Net) (kg)	Weight (Gross) (kg)
AA-CMC01U40-A-XX-YY	1U 19" KEYBOARD AND GENERAL PURPOSE STORAGE DRAWERS D=400MM	482	405	44	3,6	4
AA-CMC02U40-A-XX-YY	2U 19" KEYBOARD AND GENERAL PURPOSE STORAGE DRAWERS D=400MM	482	405	88	5,5	6
AA-CMC03U40-A-XX-YY	3U 19" KEYBOARD AND GENERAL PURPOSE STORAGE DRAWERS D=400MM	482	405	130	7,1	7,7

XX = Colour Code, B1 White RAL 7035, S1 Black RAL 9005, during order please specify the colour choice.
YY = M1 for pre-assembled, D1 for flat pack.